

# Axial piston variable pump A11V(L)O Series 40

**RE 92510**

Edition: 05.2016

Replaces: 10.2014

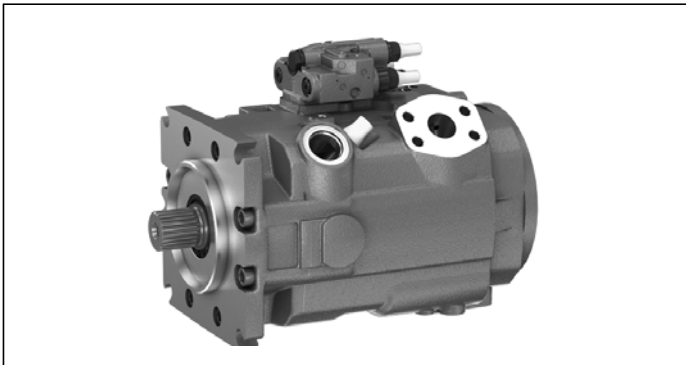

- ▶ Sizes 110 to 280
- ▶ Nominal pressure 350 bar (5100 psi)
- ▶ Maximum pressure 420 bar (6100 psi)
- ▶ Open circuit

**Features**

- ▶ Variable pump with axial piston rotary group in swash-plate design for hydrostatic drives in open circuit.
- ▶ For use preferably in mobile applications
- ▶ Flow is proportional to the drive speed and displacement.
- ▶ The flow can be infinitely varied by adjusting the swash-plate angle.
- ▶ The pump can work either self-priming or with a charge pump.
- ▶ Special control devices program for mobile applications, with different control and regulation functions.
- ▶ The universal through drive is suitable for adding gear pumps and axial piston pumps up to the same size, i.e. 100% through drive.
- ▶ Compact design
- ▶ High efficiency
- ▶ High power density
- ▶ Low noise level

**Content**

Ordering code	2
Hydraulic fluids	5
Charge pump (impeller)	6
Operating pressure range	7
Technical data	8
Power controller	12
Stroke control	18
Pressure control	22
Dimensions size 110	25
Dimensions size 145	30
Dimensions size 175	37
Dimensions size 210	44
Dimensions size 280	51
Dimensions, through drives	57
Overview of mounting options	60
Combination pumps A11V(L)O + A11V(L)O	61
Connector for solenoids	62
Installation instructions	63
Project planning notes	65
Safety instructions	65

## Ordering code

01	02	03	04	05	06	07	08	09	10	11	12	13	14	15	16	17	18	19	20	21	
<b>A11V</b>									/	<b>40</b>						<b>1</b>			<b>0</b>	-	

### Axial piston unit

01	Variable swashplate design, nominal pressure 350 bar (5100 psi), maximum pressure 420 bar (6100 psi)	<b>A11V</b>
----	--	-------------

### Operating mode

		110	145	175	210	280		
02	Pump, open circuit	without charge pump	•	•	•	•	•	<b>O</b>
		with charge pump	-	•	•	•	•	<b>LO</b>

### Size (NG)

03	Geometric displacement	cm <sup>3</sup>	110	145	175	210	280
	See the table of values, page 8	in <sup>3</sup>	<b>6.71</b>	<b>8.85</b>	<b>10.68</b>	<b>12.81</b>	<b>17.09</b>

### Control devices: basic controller<sup>1)</sup>

		110	145	175	210	280			
04	Power controller	fixed setting	•	•	•	•	•	<b>LR</b>	
		override electric-proportional	negative control	$U = 12 V$	•	•	•	•	<b>L3</b>
					$U = 24 V$	•	•	•	<b>L4</b>
		hydraulic-proportional,	negative control	•	•	•	•	•	<b>L5</b>
			positive control	•	•	•	•	•	<b>L6</b>
	Summation power controller	override hydraulic proportional, high pressure	negative control	with stop	•	•	•	•	<b>CR</b>
				without stop	•	•	•	•	<b>PR</b>
	Stroke control <sup>2)</sup>	electric-proportional	positive control	$U = 12 V$	•	•	•	•	<b>E1</b>
				$U = 24 V$	•	•	•	•	<b>E2</b>
		hydraulic-proportional, control pressure	negative control	$\Delta p = 25 \text{ bar}$	•	•	•	•	<b>H3</b>
			positive control	(365 psi)	•	•	•	•	<b>H4</b>
	Pressure control with one-side swiveling	fixed setting		•	•	•	•	•	<b>DR</b>
remote controlled hydraulically		positive control	•	•	•	•	•	<b>DG</b>	
electric-proportional with integrated pilot valve for external pilot pressure supply		positive control	$U = 24 V$	○	○	○	○	<b>D2<sup>3)</sup></b>	
Pressure control with two-side swiveling	electric-proportional with integrated pilot valve for external pilot pressure supply	positive control	$U = 24 V$	○	○	○	○	<b>M2<sup>3)</sup></b>	

### Additional control: Pressure control

		110	145	175	210	280		
05	Without additional control (without symbol)		•	•	•	•	•	
	Pressure control with one-side swiveling	fixed setting	•	•	•	•	•	<b>DR</b>
		remote controlled hydraulically	positive control	•	•	•	•	•

### Additional control: stroke control or unloading

		110	145	175	210	280			
06	Without additional control (without symbol)		•	•	•	•	•		
	Stroke control <sup>4)</sup>	electric-proportional	positive control	$U = 12 V$	•	•	•	•	<b>E1</b>
				$U = 24 V$	•	•	•	•	<b>E2</b>
		hydraulic-proportional, control pressure	negative control	$\Delta p = 25 \text{ bar}$	•	•	•	•	<b>H3</b>
			positive control	(365 psi)	•	•	•	•	<b>H4</b>

### Additional control: load sensing

		110	145	175	210	280		
07	Without additional control (without symbol)		•	•	•	•	•	
	Load sensing, internal pump pressure, fixed setting		•	•	•	•	•	<b>S0</b>

• = Available    ○ = On request    - = Not available

<sup>1)</sup> The basic controller (04) can be combined with at most two additional controllers (05, 06, 07)

<sup>2)</sup> The stroke control systems can be combined with either pressure controllers or load sensing controllers. A combination of all three controllers is not possible.

<sup>3)</sup> Not combinable with other controllers

01	02	03	04	05	06	07	08	09	10	11	12	13	14	15	16	17	18	19	20	21	
<b>A11V</b>									/	<b>40</b>						<b>1</b>			<b>0</b>	-	

**Depressurized basic position and external control pressure supply** **110 145 175 210 280**

08	Maximum swivel angle ( $V_{g \max}$ )					
	Without external control pressure supply (standard for power and pressure controllers)	●	●	●	●	●
	With external control pressure supply (integrated shuttle valve, standard for negative stroke control)	●	●	●	●	●
	Minimum swivel angle ( $V_{g \min}$ )					
	With external control pressure supply (integrated shuttle valve, standard for positive stroke control)	●	●	●	●	●

**Connectors for solenoids<sup>4)</sup>** **110 145 175 210 280**

09	Without connector (without solenoid, only for hydraulic control)					
	DEUTSCH - molded connector, 2-pin, without suppressor diode	●	●	●	●	●
	AMP connector (Junior-Timer), 2-pin (only for D2/M2 controller)	○	○	○	○	○

**Swivel angle sensor** **110 145 175 210 280**

10	Without swivel angle sensor					
	With electric swivel angle sensor <sup>5)</sup> as per data sheet 95150		Power supply 5 V DC	●	●	●
			Power supply 8 V – 32 V DC	●	●	●

**Series**

11	Series 4, index 0	<b>40</b>
----	-------------------	-----------

**Configuration of port and fastening threads**

12	Metric, all fastening threads according to DIN 13, all port threads with O-ring seal according to ISO 6149	<b>M</b>
	ANSI, all fastening threads according to ASME B1.1, all port threads with O-ring seal according to ISO 11926	<b>A</b>

**Direction of rotation** **110 145 175 210 280**

13	Viewed on drive shaft					
	clockwise	●	●	●	●	●
	counter-clockwise	●	●	●	●	●

**Sealing material** **110 145 175 210 280**

14	FKM (fluor-caoutchouc)					
		●	●	●	●	●

**Mounting flange** **110 145 175 210 280**

15	SAE J744	152-4				
		165-4	-	-	-	<b>D4</b>
			-	-	●	●
	SAE J617	409-12	○	●	●	-

**Drive shaft** (permissible input torque, see page 11) **110 145 175 210 280**

16	Splined shaft ANSI B92.1a	1 3/4 in 13T 8/16 DP				
		2 in 15T 8/16 DP	-	●	●	●
		2 1/4 in 17T 8/16 DP	-	-	-	-
	Splined shaft DIN 5480	W45x2x21x9g	●	-	-	-
		W50x2x24x9g	-	●	●	-
		W60x2x28x9g	-	-	-	-

**Working port**

17	SAE flange port A, at side (45° right), SAE flange port S at bottom	<b>1</b>
----	---	----------

**Rotary group version** **110 145 175 210 280**

18	Noise-optimized for $n = 1500/1800$ rpm, version without charge pump					
	Version with charge pump	-	●	●	●	●

● = Available    ○ = On request    - = Not available

<sup>4)</sup> Connectors for other electric components may deviate  
<sup>5)</sup> Please contact us if the swivel angle sensor is used for control

4 **A11V(L)O Series 40** | Axial piston variable pump  
Ordering code

01	02	03	04	05	06	07	08	09	10	11	12	13	14	15	16	17	18	19	20	21		
<b>A11V</b>									/	<b>40</b>							<b>1</b>			<b>0</b>	-	

**Through drives** (for attachment options, see page 61)

19	Flange SAE J744			Hub for splined shaft <sup>1)</sup>			110	145	175	210	280	
	Diameter	Attachment <sup>2)</sup>	Designation	Diameter		Designation						
82-2 (A)	☼	A3	5/8 in	9T 16/32DP	S2	●	●	●	●	●	<b>A3S2</b>	
			3/4 in	11T 16/32DP	S3	○	○	●	●	●	<b>A3S3</b>	
101-2 (B)	☼	B3	7/8 in	13T 16/32DP	S4	●	●	●	●	●	<b>B3S4</b>	
			1 in	15T 16/32DP	S5	●	●	●	●	●	<b>B3S5</b>	
	♂	B5	7/8 in	13T 16/32DP	S4	●	●	●	●	●	<b>B5S4</b>	
			1 in	15T 16/32DP	S5	○	○	●	●	○	<b>B5S5</b>	
127-2 (C)	☼	C3	1 1/4 in	14T 12/24DP	S7	○	○	●	●	●	<b>C3S7</b>	
			1 1/2 in	17T 12/24DP	S9	○	○	●	●	●	<b>C3S9</b>	
	♂	C5	1 1/4 in	14T 12/24DP	S7	○	-	●	●	●	<b>C5S7</b>	
127-4 (C)	☼☼	C4	1 1/4 in	14T 12/24DP	S7	●	●	●	●	○	<b>C4S7</b>	
			1 3/8 in	21T 16/32 DP	V8	○	○	○	○	○	<b>C4V8</b>	
152-4 (D)	☼☼	D4	1 1/4 in	14T 12/24DP	S7	○	○	○	○	○	<b>D4S7</b>	
			1 3/8 in	21T 16/32 DP	V8	○	○	○	○	○	<b>D4V8</b>	
			1 3/4 in	13T 8/16DP	T1	●	●	●	●	●	<b>D4T1</b>	
165-4 (E)	☼☼	E4	1 3/4 in	13T 8/16DP	T1	-	-	●	●	●	<b>E4T1</b>	
			2 in	15T 8/16DP	T2	-	-	●	●	●	<b>E4T2</b>	
			2 1/4 in	17T 8/16DP	T3	-	-	-	-	●	<b>E4T3</b>	
			W60x2x28x9g <sup>3)</sup>	A4	-	-	-	-	●	<b>E4A4</b>		
Prepared for through drive, with pressure-proof plugged cover (also see data sheet 95581)						●	●	●	●	●	<b>U000</b>	

**Pressure sensors and other sensors**

20	Without sensor	<b>0</b>
----	----------------	----------

**Standard/special version**

21	Standard version	<b>0</b>
	Special version	<b>S</b>

● = Available    ○ = On request    - = Not available

**Note**

- ▶ Note the project planning notes on page 66.
- ▶ In addition to the ordering code, please specify the relevant technical data when placing your order.

1) According to ANSI B92.1a

2) Mounting bores pattern viewed from through drive with control at top

3) Hub N60x2x28x8H according to DIN 5480



## Hydraulic fluids

The A11V(L)O variable pump is designed for operation with HLP mineral oil according to DIN 51524.

Application instructions and requirements for hydraulic fluids should be taken from the following data sheets before the start of project planning:

- ▶ 90220: Hydraulic fluids based on mineral oils and related hydrocarbons
- ▶ 90221: Environmentally acceptable hydraulic fluids
- ▶ 90222: Fire-resistant, water-free hydraulic fluids (HFDR/HFDU)

### Notes on selection of hydraulic fluid

The hydraulic fluid should be selected such that the operating viscosity in the operating temperature range is within the optimum range ( $v_{opt}$  see selection diagram).

#### Notice

At no point of the component may the temperature be higher than 115 °C (240 °F). The temperature difference specified in the table is to be taken into account when determining the viscosity in the bearing. If the above conditions cannot be maintained due to extreme operating parameters, please contact the responsible member of staff at Bosch Rexroth.

### Viscosity and temperature of hydraulic fluids

	Viscosity	Temperature	Comment
Cold start/ Warm-up phase	$v = 1600$ to $400$ mm <sup>2</sup> /s ( $v < 7400$ to $1850$ SUS)	$\theta = -40$ °C to $-25$ °C ( $\theta = -40$ °F to $-13$ °F)	At low load ( $20 \text{ bar} \leq p < 50 \text{ bar}$ ) $n \leq 1000$ rpm
Permissible temperature difference		$\Delta T \leq 25$ K (45 °F)	between axial piston unit and hydraulic fluid
Standard operating conditions and continuous operation at $v_{opt}$	$v = 400$ to $10$ mm <sup>2</sup> /s ( $v = 1850$ to $60$ SUS)	$\theta = -25$ °C to $+110$ °C ( $\theta = -13$ °F to $+230$ °F)	This corresponds, for example on the VG 46, to a temperature range of $+5$ °C (41 °F) to $+85$ °C (185 °F) (see selection diagram) measured at port <b>T</b> observe the permissible temperature range of the shaft seal ring ( $\Delta T =$ about 5 K (9 °F) between bearing/shaft seal ring and port <b>T</b> )
	$v_{opt} = 36$ to $16$ mm <sup>2</sup> /s ( $v_{opt} = 170$ to $74$ SUS)	$\theta = -25$ °C to $+110$ °C ( $\theta = -13$ °F to $+230$ °F)	optimal operating viscosity and efficiency measured at port <b>T</b>
Short-term operation	$v_{min} \geq 7$ mm <sup>2</sup> /s (50 SUS)		$t < 3$ min, $p < 0.3 \times p_{nom}$

### ▼ Selection diagram

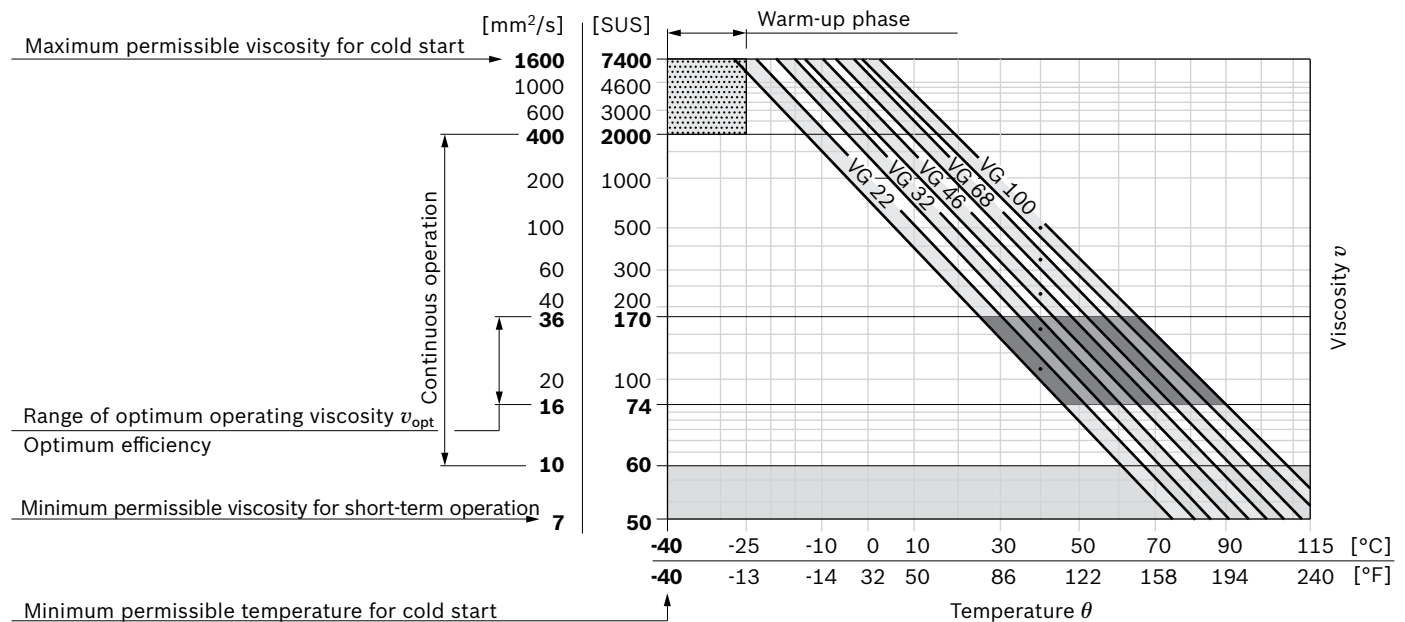

1) At temperatures below  $-25$  °C ( $-13$  °F) an NBR shaft seal is required (permissible temperature range  $-40$  °C to  $+90$  °C ( $-40$  °F to  $+195$  °F)), please contact us (ordering code 14, letter K).

### Filtration of the hydraulic fluid

Finer filtration improves the cleanliness level of the hydraulic fluid, which increases the service life of the axial piston unit. A cleanliness level of at least 20/18/15 is to be maintained according to ISO 4406.

At very high hydraulic fluid temperatures (90 °C (195 °F) to maximum 115 °C (240 °F)), a cleanliness class of at least 19/17/14 according to ISO 4406 is necessary.

Please contact us if the above classes cannot be observed.

### Charge pump (impeller)

The charge pump is a circulating pump with which the A11VLO is filled and therefore can be operated at higher speeds. This also simplifies cold starting at low temperatures and high viscosity of the hydraulic fluid. Externally increasing the inlet pressure is therefore unnecessary in most cases. Charging the reservoir with compressed air is not permissible.

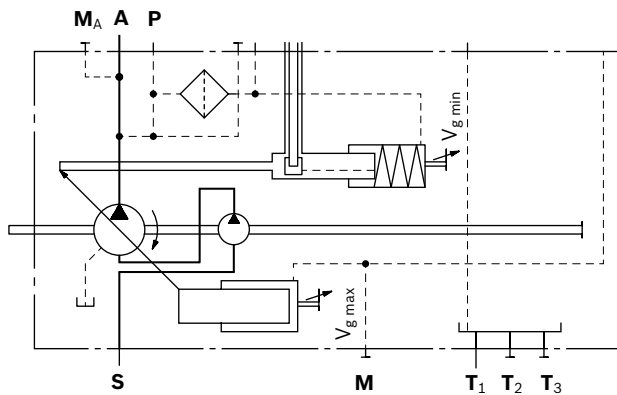

## Operating pressure range

Pressure at working line port A		Definition
Nominal pressure $p_{nom}$	350 bar (5100 psi)	The nominal pressure corresponds to the maximum design pressure.
Maximum pressure $p_{max}$	420 bar (6100 psi)	The maximum pressure corresponds to the maximum operating pressure within the single operating period. The sum of the single operating periods must not exceed the total operating period.
Single operating period	10 s	
Total operating period	300 h	
Minimum pressure $p_{A abs}$ (High-pressure side)		Minimum pressure at the high-pressure side (A) which is required in order to prevent damage to the axial piston unit. The minimum pressure depends on the rotational speed and the swivel angle (see diagram).
Rate of pressure change $R_{A max}$	16000 bar/s (232000 psi/s)	Maximum permissible rate of pressure build-up and reduction during a pressure change across the entire pressure range.
Pressure at suction port S (inlet)		
Version without charge pump		Minimum pressure at suction port S (inlet) that is required in order to avoid damage to the axial piston unit. The minimum pressure depends on the speed and displacement of the axial piston unit.
Minimum pressure $p_{S min}$	$\geq 0.8$ bar (12 psi) absolute	
Maximum pressure $p_{S max}$	$\leq 30$ bar (435 psi)	
Version with charge pump		
Minimum pressure $p_{S min}$	$\geq 0.7$ bar (10.5 psi) absolute	
Maximum pressure $p_{S max}$	$\leq 2$ bar (30 psi) absolute	
Case pressure at port T <sub>1</sub> , T <sub>2</sub> , T <sub>3</sub>		
Maximum static pressure $p_{L max}$	3 bar (45 psi)	Maximum 1.2 bar (18 psi) higher than inlet pressure at port S, but not higher than $p_{L max}$ . A case drain line to the reservoir is required.
Pressure peaks $p_{L peak}$	6 bar (90 psi)	$t < 0.1s$

### ▼ Rate of pressure change $R_{A max}$

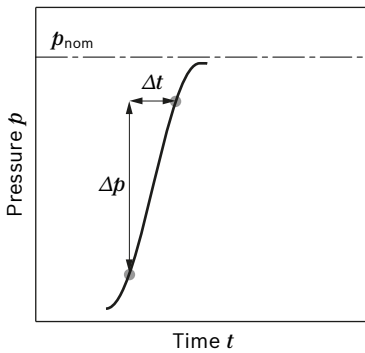

### ▼ Pressure definition

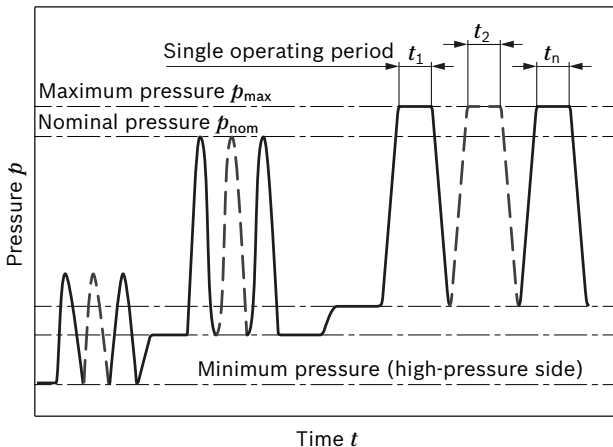

Total operating period =  $t_1 + t_2 + \dots + t_n$

### ▼ Minimum pressure (high-pressure side)

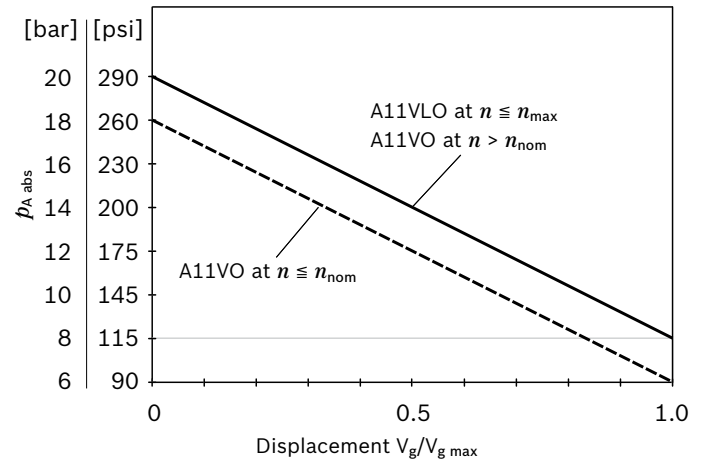

### Notice

Operating pressure range valid when using hydraulic fluids based on mineral oils. Values for other hydraulic fluids, please contact us.

## Technical data

### Without charge pump (A11VO)

Size	NG		110	145	175	210	280		
Displacement, geometric, per revolution	$V_{g \max}$	cm <sup>3</sup>	110.0	145.0	175.0	210.0	280.0		
		in <sup>3</sup>	6.71	8.85	10.68	12.81	17.09		
	$V_{g \min}$	cm <sup>3</sup>	0	0	0	0	0		
		in <sup>3</sup>	0	0	0	0	0		
Speed maximum <sup>1)</sup>	at $V_{g \max}$ <sup>2)</sup>	$n_{\text{nom}}$	rpm	2400	2300	2150	2100	1800	
	at $V_g \leq V_{g \max}$ <sup>3)</sup>	$n_{\text{max}}$	rpm	2800	2600	2500	2500	2300	
Flow	at $n_{\text{nom}}$ and $V_{g \max}$	$q_v$	l/min	264	334	376	441	504	
			gpm	70	88	99	117	133	
Power	at $n_{\text{nom}}$ , $V_{g \max}$ and $\Delta p = 350$ bar (5100 psi)	$P$	kW	154	195	219	257	294	
			hp	207	261	294	345	394	
Torque	at $V_{g \max}$ and $\Delta p = 350$ bar (5100 psi) <sup>2)</sup>	$T$	Nm	613	808	975	1170	1560	
			lb-ft	452	596	719	863	1151	
Rotary stiffness of drive shaft	1 3/4 in 13T 8/16 DP	T1	$c$	kNm/rad	–	235	243	254	–
				lb-ft/rad	–	173327	179227	187340	–
	2 in 15T 8/16 DP	T2	$c$	kNm/rad	–	286	298	314	–
				lb-ft/rad	–	210942	219794	231595	–
	2 1/4 in 17T 8/16 DP	T3	$c$	kNm/rad	–	–	–	–	519
				lb-ft/rad	–	–	–	–	382795
	W45x2x21x9g	A1	$c$	kNm/rad	242	–	–	–	–
				lb-ft/rad	178489	–	–	–	–
	W50x2x24x9g	A2	$c$	kNm/rad	–	334	357	381	–
				lb-ft/rad	–	246345	263309	281011	–
	W60x2x28x9g	A4	$c$	kNm/rad	–	–	–	–	645
				lb-ft/rad	–	–	–	–	475727
Moment of inertia for rotary group		$J_{\text{TW}}$	kgm <sup>2</sup>	0.022	0.035	0.045	0.06	0.097	
			lb-ft <sup>2</sup>	0.5221	0.8306	1.0679	1.4238	2.3019	
Maximum angular acceleration <sup>4)</sup>		$\alpha$	rad/s <sup>2</sup>	7465	6298	5609	5014	4200	
Case volume		$V$	l	2.2	2.7	3.6	4	6.5	
			gal	0.58	0.71	0.95	1.06	1.72	
Weight (without through drive) about		$m$	kg	64	79	97	111	143	
			lbs	141	174	214	245	315	

- 1) The values are applicable:
- for the optimum viscosity range from  $\nu_{\text{opt}} = 36$  to  $16$  mm<sup>2</sup>/s (170 to 74 SUS)
  - with hydraulic fluid based on mineral oils
- 2) The values apply at absolute pressure  $p_{\text{abs}} = 1$  bar (15 psi) at suction port **S**.
- 3) Maximum rotational speed (rotational speed limit) in the case of increasing the inlet pressure  $p_{\text{abs}}$  at suction port **S** and  $V_g < V_{g \max}$ , see diagram on page 10.

- 4) The data are valid for values between the minimum required and maximum permissible rotational speed. Valid for external excitation (e.g. diesel engine 2 to 8 times rotary frequency; cardan shaft twice the rotary frequency). The limit value is only valid for a single pump. The load capacity of the connecting parts must be considered.

**With charge pump (A11VLO)**

Size	NG		145	175	210	280		
Displacement, geometric, per revolution	$V_{g \max}$	cm <sup>3</sup>	145.0	175.0	210.0	280.0		
		in <sup>3</sup>	8.85	10.68	12.81	17.09		
	$V_{g \min}$	cm <sup>3</sup>	0	0	0	0		
		in <sup>3</sup>	0	0	0	0		
Speed maximum <sup>1)</sup>	at $V_{g \max}$ <sup>2)</sup>	$n_{\text{nom}}$	rpm	2600	2500	2500	2300	
	at $V_g \leq V_{g \max}$ <sup>3)</sup>	$n_{\text{max}}$	rpm	2600	2500	2500	2300	
Flow	at $n_{\text{nom}}$ and $V_{g \max}$	$q_v$	l/min	377	438	525	644	
			gpm	100	116	139	170	
Power	at $n_{\text{nom}}$ , $V_{g \max}$ and $\Delta p = 350$ bar (5100 psi)	$P$	kW	220	255	306	376	
			hp	295	342	410	504	
Torque	at $V_{g \max}$ and $\Delta p = 350$ bar (5100 psi) <sup>2)</sup>	$T$	Nm	808	975	1170	1560	
			lb-ft	596	719	863	1151	
Rotary stiffness of drive shaft	1 3/4 in 13T 8/16 DP	T1	$c$	kNm/rad	235	243	254	–
				lb-ft/rad	173327	179227	187340	–
	2 in 15T 8/16 DP	T2	$c$	kNm/rad	286	298	314	–
				lb-ft/rad	210942	219794	231595	–
	2 1/4 in 17T 8/16 DP	T3	$c$	kNm/rad	–	–	–	519
				lb-ft/rad	–	–	–	382795
	W50x2x24x9g	A2	$c$	kNm/rad	334	357	381	–
				lb-ft/rad	246345	263309	281011	–
	W60x2x28x9g	A4	$c$	kNm/rad	–	–	–	645
				lb-ft/rad	–	–	–	475727
	Moment of inertia for rotary group		$J_{\text{TW}}$	kgm <sup>2</sup>	0.035	0.047	0.063	0.097
				lb-ft <sup>2</sup>	0.8306	1.0679	1.4238	2.3019
Maximum angular acceleration <sup>4)</sup>		$\alpha$	rad/s <sup>2</sup>	6298	5609	5014	4200	
Case volume		$V$	l	2.9	3.6	3.7	5.6	
			gpm	0.77	0.95	0.98	1.48	
Weight (without through drive) about		$m$	kg	92	110	125	148	
			lbs	203	243	276	326	

- 1) The values are applicable:
  - for the optimum viscosity range from  $\nu_{\text{opt}} = 36$  to  $16 \text{ mm}^2/\text{s}$  (170 to 74 SUS)
  - with hydraulic fluid based on mineral oils
- 2) The values apply at absolute pressure  $p_{\text{abs}} = 1$  bar (15 psi) at suction port **S**.
- 3) Maximum rotational speed (rotational speed limit) in the case of increasing the inlet pressure  $p_{\text{abs}}$  at suction port **S** and  $V_g < V_{g \max}$ , see diagram on page 10.

- 4) The data are valid for values between the minimum required and maximum permissible rotational speed. Valid for external excitation (e.g. diesel engine 2 to 8 times rotary frequency; cardan shaft twice the rotary frequency). The limit value is only valid for a single pump. The load capacity of the connecting parts must be considered.

▼ **Maximum permissible rotational speed (rotational speed limit)**  
 ( $p_{s\ abs}$  = inlet pressure [bar (psi)])

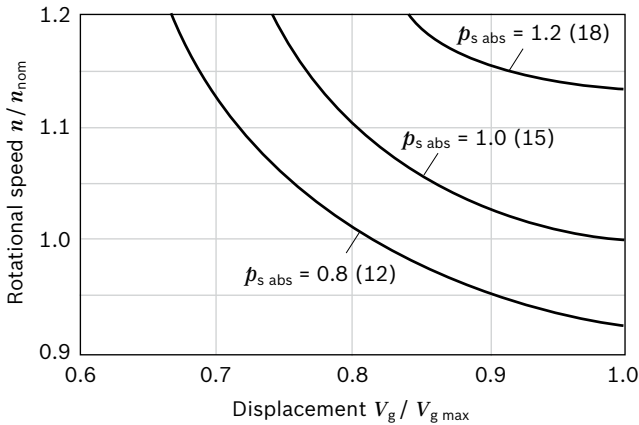

**Determining the operating characteristics**

Flow	$q_v = \frac{V_g \times n \times \eta_v}{1000}$	[l/min]
	$q_v = \frac{V_g \times n \times \eta_v}{231}$	[gpm]
Torque	$T = \frac{V_g \times \Delta p}{20 \times \pi \times \eta_{hm}}$	[Nm]
	$T = \frac{V_g \times \Delta p}{24 \times \pi \times \eta_{hm}}$	[lb-ft]
Power	$P = \frac{2 \pi \times T \times n}{60000} = \frac{q_v \times \Delta p}{600 \times \eta_t}$	[kW]
	$P = \frac{2 \pi \times T \times n}{33000} = \frac{q_v \times \Delta p}{1714 \times \eta_t}$	[hp]

Key

$V_g$	=	Displacement per revolution [cm <sup>3</sup> (in <sup>3</sup> )]
$\Delta p$	=	Differential pressure [bar (psi)]
$n$	=	Rotational speed [rpm]
$\eta_v$	=	Volumetric efficiency
$\eta_{hm}$	=	Hydraulic-mechanical efficiency
$\eta_t$	=	Total efficiency ( $\eta_t = \eta_v \times \eta_{hm}$ )

**Permissible radial and axial forces of the drive shafts**

Size	NG	110	110	145	145	145	175	175	175	210	210	210	280	280	
Drive shaft		1 3/4 in	W45	1 3/4 in	2 in	W50	1 3/4 in	2 in	W50	1 3/4 in	2 in	W50	2 1/4 in	W60	
Maximum radial force at distance a (from shaft collar)	$F_{q\ max}$	N	8000	8000	11000	11000	11000	12300	12300	14000	16925	16925	17000	18000	23600
		lb	1798	1798	2473	2473	2473	2765	2765	3147	3805	3805	3822	4046	5305
	a	mm	33.5	25	33.5	40	27.5	33.5	40	27	33.5	40	27	40	29
		in	1.32	0.98	1.32	1.57	1.08	1.32	1.57	1.06	1.32	1.57	1.06	1.57	1.14
Maximum axial force	$+ F_{ax\ max}$	N	1200	1200	1350	1350	1350	1400	1400	1400	1450	1450	1450	1800	1800
		lb	270	270	304	304	304	315	315	315	326	326	326	405	405
$F_{ax}$	$- F_{ax\ max}$	N	500	500	600	600	600	650	650	650	700	700	700	850	850
		lb	112	112	135	135	135	146	146	146	157	157	157	191	191

**Note**

- ▶ Theoretical values, without efficiency and tolerances; values rounded
- ▶ Operation above the maximum values or below the minimum values may result in a loss of function, a reduced service life or in the destruction of the axial piston unit. We recommend testing the loads by means of experiment or calculation / simulation and comparison with the permissible values.
- ▶ Special requirements apply in the case of belt drives. Please contact us.

**Permissible input and through-drive torques**

Size	NG	110	145	175	210	280		
Torque at $V_{g \max}$ and $\Delta p = 350 \text{ bar}$ (5100 psi) <sup>1)</sup>	$T_{\max}$	Nm	610	808	975	1170	1560	
		lb-ft	452	596	719	863	1151	
Input torque at drive shaft, maximum <sup>2)</sup>								
T1	1 3/4 in	$T_{E \max}$	Nm	1640	1640	1640	1640	–
			lb-ft	1210	1210	1210	1210	–
T2	2 in	$T_{E \max}$	Nm	–	2670	2670	2670	–
			lb-ft	–	1969	1969	1969	–
T3	2 1/4 in	$T_{E \max}$	Nm	–	–	–	–	4380
			lb-ft	–	–	–	–	3231
A1	W45	$T_{E \max}$	Nm	2190	–	–	–	–
			lb-ft	–	–	–	–	–
A2	W50	$T_{E \max}$	Nm	–	3140	3140	3140	–
			lb-ft	–	2316	2316	2316	–
A4	W60	$T_{E \max}$	Nm	–	–	–	–	5780
			lb-ft	–	–	–	–	4263
Maximum through-drive torque	$T_{D \max}$	Nm	960	1110	1340	1915	2225	
		lb-ft	708	819	988	1412	1641	

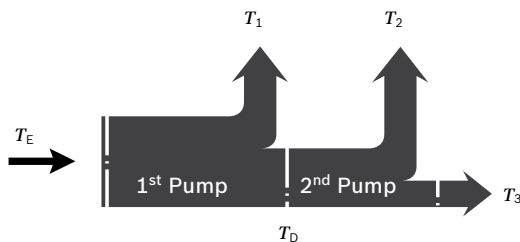
**▼ Distribution of the torques**

Torque at 1 <sup>st</sup> pump	$T_1$
Torque at 2 <sup>nd</sup> pump	$T_2$
Torque at 3 <sup>rd</sup> pump	$T_3$
Input torque	$T_E = T_1 + T_2 + T_3$
	$T_E < T_{E \max}$
Through-drive torque	$T_D = T_2 + T_3$
	$T_D < T_{D \max}$

**External control pressure supply  
(ordering code digit 08 B and C)**

Control systems with external control pressure supply need a flow appropriate to the adjustment time and size.

Size	Maximum flow [l/min (gpm)]
110	10 (2.64)
145	13 (3.43)
175	14 (3.70)
210	17 (4.49)
280	22 (5.81)

- 1) Efficiency not considered
- 2) For drive shafts free of radial force

## Power controller

### LR – Power controller, fixed setting

The power controller regulates the displacement of the pump depending on the operating pressure so that a given drive power is not exceeded at constant drive speed. The precise control with a hyperbolic control characteristic, provides an optimum utilization of available power. The operating pressure acts on a rocker via a measuring piston moved together with the control. An externally adjustable spring force counteracts this, it determines the power setting. The depressurized basic position is  $V_{g \max}$ . If the operating pressure exceeds the set spring force, the control valve will be actuated by the rocker and the pump will swivel back from the basic setting  $V_{g \max}$  toward  $V_{g \min}$ . Here, the leverage at the rocker may be shortened and the operating pressure may rise in the same relation as the displacement is reduced ( $p_B \times V_g = \text{constant}$ ;  $p_B =$  operating pressure;  $V_g =$  displacement). The hydraulic output power (characteristic LR) is influenced by the efficiency of the pump. Setting range for beginning of control 50 bar (725 psi) to 350 bar (5100 psi).

When ordering, state in plain text:

- ▶ Drive power  $P$  [kW]
- ▶ Drive speed  $n$  [rpm]
- ▶ Maximum flow  $q_{V \max}$  [l/min]

Please contact us if you need a power diagram.

### ▼ Characteristic LR

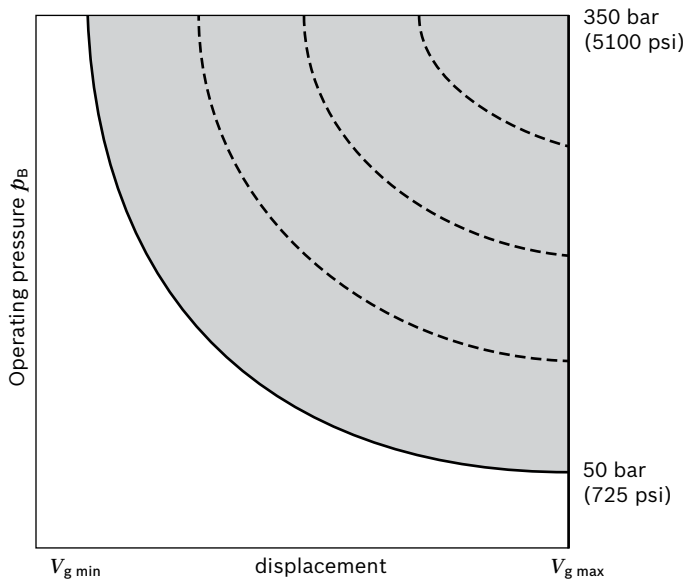

### ▼ Circuit diagram LR

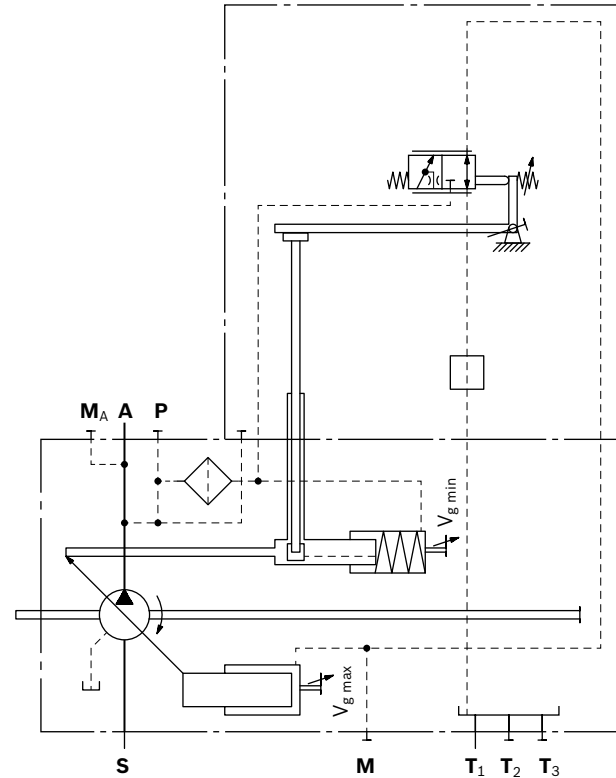



**L3/L4 – Power controller, electric-proportional override (negative control)**

A control current acts against the adjustment spring of the power controller via a proportional solenoid.

The mechanically adjusted basic power setting can be reduced by means of different control current settings.

Increasing control current = reduced power.

If the pilot control signal is variably controlled via a load limiting control, the power draw of all consumers is adjusted to the power draw possible for the diesel engine (e.g. electronic load limiting control LLC (data sheet 95310) in BODAS controller RC2-2).

Technical data, solenoid	L3	L4
Voltage	12 V (±20%)	24 V (±20%)
Control current		
Beginning of control	400 mA	200 mA
End of control	1200 mA	600 mA
Current limit	1.54 A	0.77 A
Nominal resistance (at 20 °C (68 °F))	5.5 Ω	22.7 Ω
Dither frequency	100 Hz	100 Hz
Duty cycle	100%	100%
Type of protection: see connector version page 63		

When ordering, state in plain text:

- ▶ Drive power  $P$  [kW (hp)] at beginning of control
- ▶ Drive speed  $n$  [rpm]
- ▶ Maximum flow  $q_{V \max}$  [l/min (gpm)]

▼ **Effect of power override through current increase or de-energized operating condition**

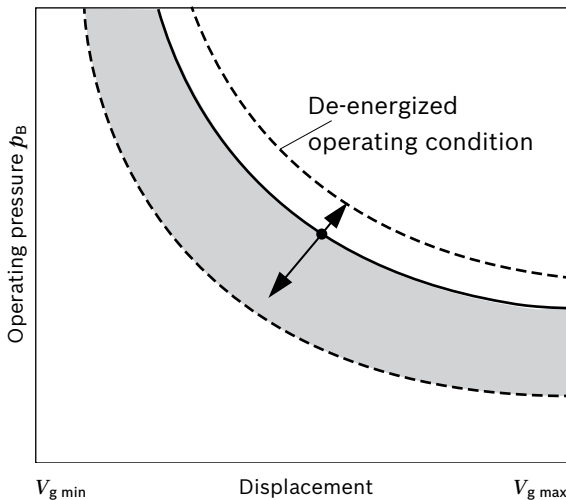

**Notice**

In operating condition **L3** de-energized (jump 400 to 0 mA): Power increase by a factor of 2 of the table values.

In operating condition **L4** de-energized (jump 200 to 0 mA): Power increase by a factor of 1 of the table values.

▼ **Circuit diagram L3/L4**

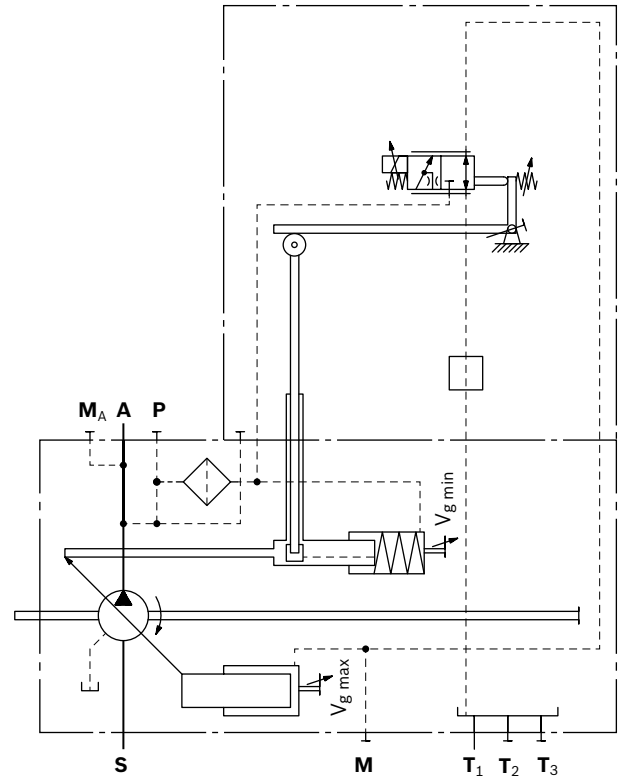

Reduction of power by control current to the proportional solenoids with **L3**<sup>1)</sup>

**Power reduction/control current [kW (hp)/100 mA]**

Size	Speed [rpm]		
	1000	1500	1800
<b>110</b>	6.1 (8.2)	9.2 (12.3)	11.0 (14.7)
<b>145</b>	7.4 (9.9)	11.1 (14.9)	13.3 (17.8)
<b>175</b>	8.4 (11.3)	12.6 (16.9)	15.1 (20.2)
<b>210</b>	9.4 (12.6)	14.1 (18.9)	16.9 (22.7)
<b>280</b>	11.4 (15.3)	17.1 (22.9)	20.5 (27.5)

Reduction of power by control current to the proportional solenoids with **L4**<sup>1)</sup>

**Power reduction/control current [kW (hp)/100 mA]**

Size	Speed [rpm]		
	1000	1500	1800
<b>110</b>	12.3 (16.5)	18.5 (24.8)	22.1 (29.6)
<b>145</b>	14.8 (19.8)	22.2 (29.8)	26.6 (35.7)
<b>175</b>	16.8 (22.5)	25.2 (33.8)	30.2 (40.5)
<b>210</b>	18.9 (25.3)	28.4 (38.1)	34.0 (45.6)
<b>280</b>	22.9 (30.7)	34.4 (46.1)	41.2 (55.3)

1) Values in the tables are reference points. Determination of the exact power override on request.

**L5 – Power controller, hydraulic-proportional override (negative control)**

A pilot pressure acts against the adjustment spring of the power controller via a valve.

The mechanically adjusted basic power setting can be reduced by means of different pilot pressure settings.

Increasing pilot pressure = reduced power.

- ▶ Maximum permissible pilot pressure

$$p_{St \max} = 100 \text{ bar (1450 psi)}$$

If the pilot pressure signal is adjusted by a load limiting control, the power reduction of all consumers is reduced to match the available power from the diesel engine.

Reduction of power by pilot pressure at port **L5**

**Power reduction/control current [kW (hp)/bar (psi)]**

Size	Speed [rpm]		
	1000	1500	1800
<b>110</b>	2.3 (3.1)	3.5 (4.7)	4.1 (5.5)
<b>145</b>	2.8 (3.8)	4.2 (5.6)	5.0 (6.7)
<b>175</b>	3.2 (4.3)	4.8 (6.4)	5.8 (7.8)
<b>210</b>	3.6 (4.8)	5.4 (5.9)	6.5 (8.7)
<b>280</b>	4.4 (5.9)	6.6 (8.9)	7.9 (10.6)

Values in the tables are reference points. Determination of the exact power override on request.

When ordering, state in plain text:

- ▶ Drive power  $P$  [kW (hp)] at a pilot pressure of  $p_{st}$  in **L5** of 5 bar (75 psi)
- ▶ Drive speed  $n$  [rpm]
- ▶ Maximum flow  $q_{V \max}$  [l/min (gpm)]

▼ **Effect of power override through pilot pressure increase**

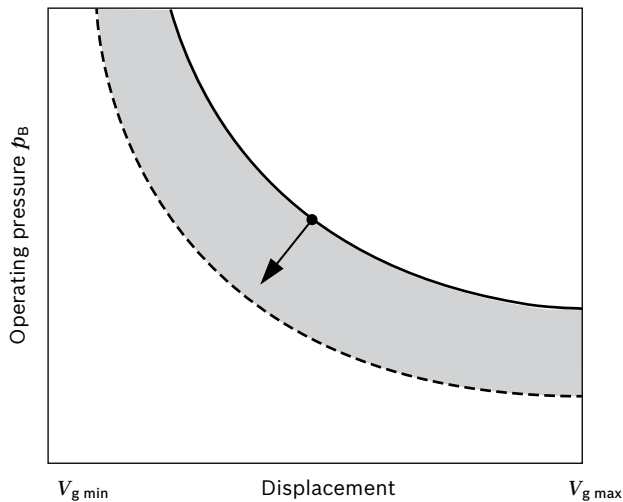

▼ **Circuit diagram L5**

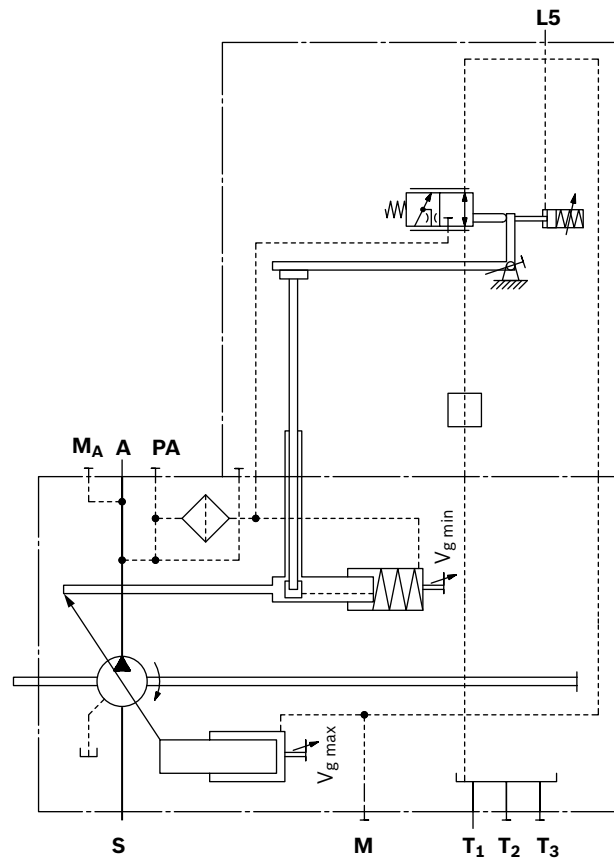

**L6 – Power controller, hydraulic-proportional override (positive control)**

A pilot pressure acts together with the adjustment spring of the power controller via a valve.

The mechanically adjusted basic power setting can be increased by means of different pilot pressure settings.

Increasing pilot pressure = increased power.

- ▶ Maximum permissible pilot pressure

$$p_{St \max} = 100 \text{ bar (1450 psi)}$$

If the pilot pressure signal is adjusted by a load limiting control, the power increase of all consumers is increased to match the available power from the diesel engine.

Power increase by pilot pressure at port **L6**

**Power increase/pilot pressure [kW (hp)/bar (psi)]**

Size	Speed [rpm]		
	1000	1500	1800
<b>110</b>	2.4 (3.2)	3.6 (4.8)	4.3 (5.8)
<b>145</b>	2.9 (3.9)	4.3 (5.8)	5.2 (7.0)
<b>175</b>	3.3 (4.4)	4.9 (6.6)	5.9 (7.9)
<b>210</b>	3.7 (5.0)	5.6 (7.5)	6.7 (9.0)
<b>280</b>	4.5 (6.0)	6.8 (9.1)	8.1 (10.9)

Values in the tables are reference points. Determination of the exact power override on request.

When ordering, state in plain text:

- ▶ Drive power  $P$  [kW (hp)] at a pilot pressure of  $p_{st}$  in **L6** of 5 bar (75 psi)
- ▶ Drive speed  $n$  [rpm]
- ▶ Maximum flow  $q_{V \max}$  [l/min (gpm)]

▼ **Effect of power override through pilot pressure increase**

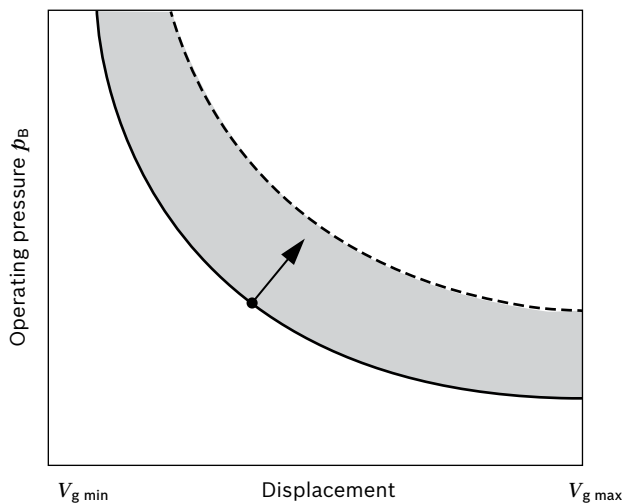

▼ **Circuit diagram L6**

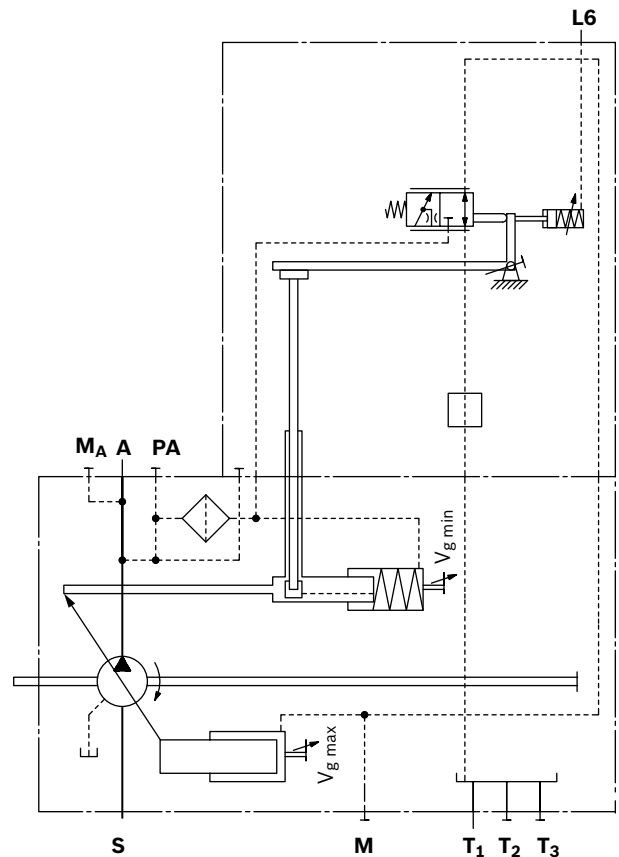

**CR – Summation hp-control of two power-controlled pumps, high-pressure-related override (with stop)**

With two pumps of the same size working in different circuits, the CR controller limits the overall power. The CR works like the normal LR with a fixed maximum power setting along the power hyperbola. The high-pressure-related override reduces the power setpoint in dependence on the operating pressure of the other pump. That happens proportionally below the beginning of control and is blocked by a stop when the minimum power is reached. Here, the **CR** port of the one pump has to be connected to the **M<sub>A</sub>** port of the other pump.

The maximum power of the first pump is reached when the second pump is working at idle when depressurized. When defining the maximum power, the idle power of the second pump has to be taken into account. The minimum power of each pump is reached when both pumps are working at high pressure. The minimum power usually equates to 50% of the total power.

Power that is released by the pressure control or other overrides remains unconsidered.

Setting range for beginning of control 50 bar (725 psi) to 300 bar (4350 psi).

When ordering, please specify separately for each pump:

- ▶ Maximum drive power  $P_{max}$  [kW (hp)]
- ▶ Minimum drive power  $P_{min}$  [kW (hp)]
- ▶ Drive speed  $n$  [rpm]
- ▶ Maximum flow  $q_{V max}$  [l/min (gpm)]

▼ **Characteristic CR**

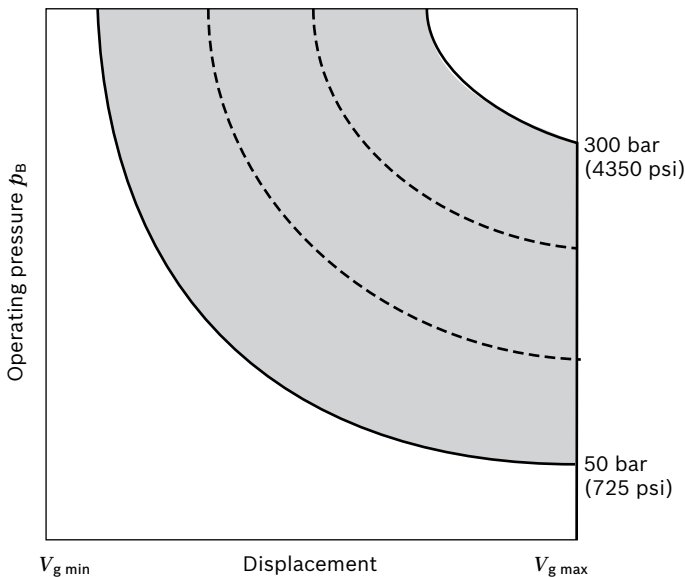

▼ **Circuit diagram CR**

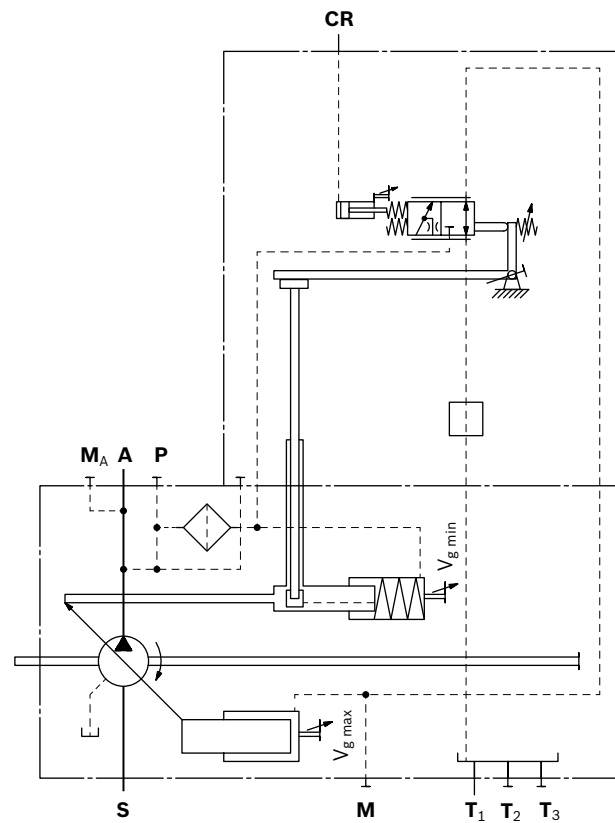

▼ **Effect of power override of a pump with increasing pressure in the 2<sup>nd</sup> pump**

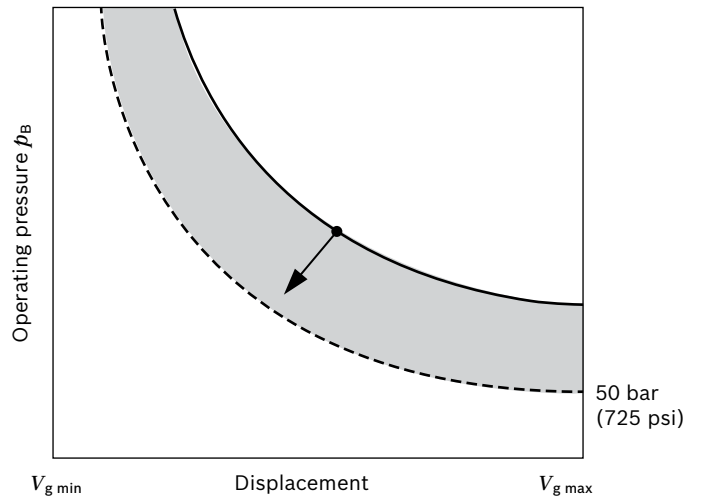

**PR – Summation hp-control of two power-controlled pump and a constant pump**

Together with the mounted fixed pump, the PR controller on an A11V(L)O effects a limitation of the overall power. The PR works like the normal LR with a fixed maximum power setting along the power hyperbola. The high-pressure-dependent override reduces the power specification in proportion to the operating pressure of the fixed pump. Here, port **PR** of the A11V(L)O must be connected to the operating pressure of the fixed pump. The power of the controlled pump can then be reduced to zero in a borderline case. The maximum power of the controlled pump is reached when the fixed pump works at idle when depressurized. When defining the maximum power, the idle power of the fixed pump has to be taken into account. Power that is released by the pressure control or other overrides remains unconsidered. Setting range for beginning of control 50 bar (725 psi) to 350 bar (5100 psi).

When ordering, state in plain text:

- ▶ Maximum drive power  $P_{max}$  [kW (hp)]
- ▶ Drive speed  $n$  [rpm]
- ▶ Maximum flow  $q_{Vmax}$  [l/min (gpm)]
- ▶ Size of the fixed pump

▼ **Characteristic PR**

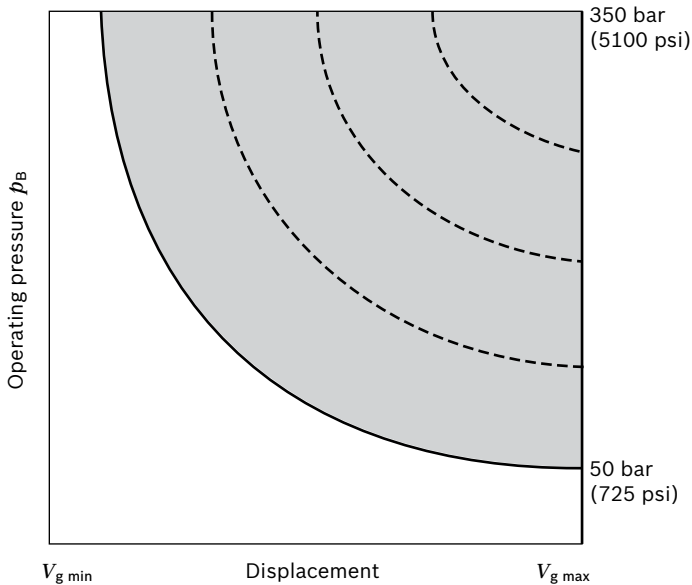

▼ **Circuit diagram PR**

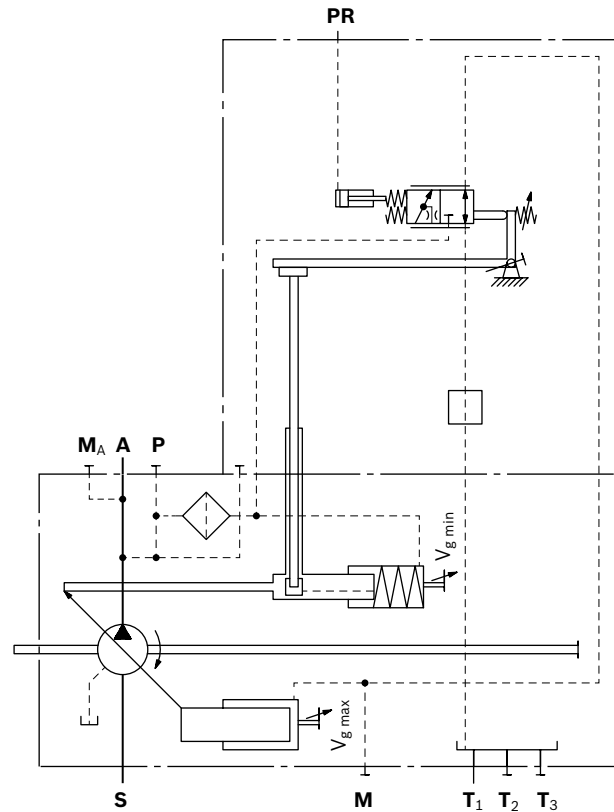

▼ **Effect of power override of a pump with increasing pressure in the 2<sup>nd</sup> pump**

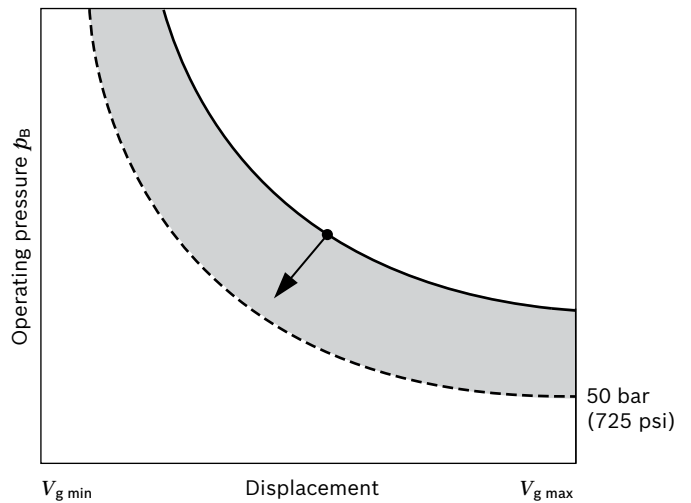

## Stroke control

### E1/E2 – Stroke control, electric, proportional (positive control)

With the electrical stroke limiter with proportional solenoid, the pump displacement is steplessly adjusted in proportion to the current via the magnetic force.

Basic position without pilot signal is  $V_{g \min}$ . Mechanically depressurized basic position is  $V_{g \min}$  (see ordering code position 08, letter C).

With increasing control current the pump swivels to a higher displacement (from  $V_{g \min}$  to  $V_{g \max}$ ).

The necessary control fluid is taken from the operating pressure or the external control pressure applied to port **P**. If the pump is to be adjusted from the basic position  $V_{g \min}$  or from a low operating pressure, port **P** must be supplied with an external control pressure of at least 30 bar (435 psi), maximum 50 bar (725 psi).

#### Notice

If there is no external control pressure applied to **P**, the version “Maximum swivel angle ( $V_{g \max}$ ), without external control pressure supply” must be ordered (see ordering code position 08, A).

#### ▼ Characteristic E1/E2

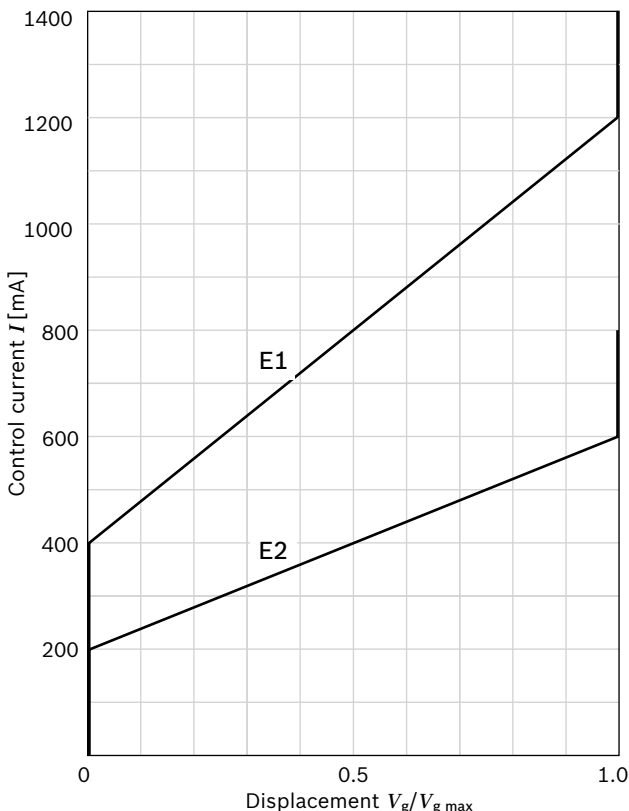

Various BODAS controllers with application software and amplifiers are available for controlling the proportional solenoids.

- ▶ RC series 30, data sheet 95204
- ▶ RC series 30, data sheet 95205

Further information can also be found on the Internet at [www.boschrexroth.com/mobile-electronics](http://www.boschrexroth.com/mobile-electronics).

Technical data, solenoid	E1	E2
Voltage	12 V (±20%)	24 V (±20%)
Control current		
Start of control at $V_{g \min}$	400 mA	200 mA
End of control at $V_{g \max}$	1200 mA <sup>1)</sup>	600 mA <sup>2)</sup>
Current limit	1.54 A	0.77 A
Nominal resistance (at 20 °C (68 °F))	5.5 Ω	22.7 Ω
Dither frequency	100 Hz	100 Hz
Duty cycle	100%	100%
Type of protection: see connector version page 63		

When ordering, state in plain text:

- ▶ Drive speed  $n$  [rpm]
- ▶ Maximum flow  $q_{V \max}$  [l/min (gpm)]
- ▶ Minimum flow  $q_{V \min}$  [l/min (gpm)]

See circuit diagram on page 19

#### Notice!

The spring feedback in the controller is not a security device. The controller can stick in an undefined position due to internal contamination (contaminated hydraulic fluid, abrasion or residual contamination from system components). As a result, the flow of the axial piston unit will no longer respond correctly to the operator's commands. Check whether the application on your machine requires additional safety measures, in order to bring the driven consumer into a safe position (immediate stop). If necessary, make sure that these are properly implemented.

- 1) Because of the control hysteresis, a control current of up to 1300 mA may be required for the  $V_{g \max}$  position.
- 2) Because of the control hysteresis, a control current of up to 650 mA may be required for the  $V_{g \max}$  position.

▼ **Circuit diagram E1/E2**

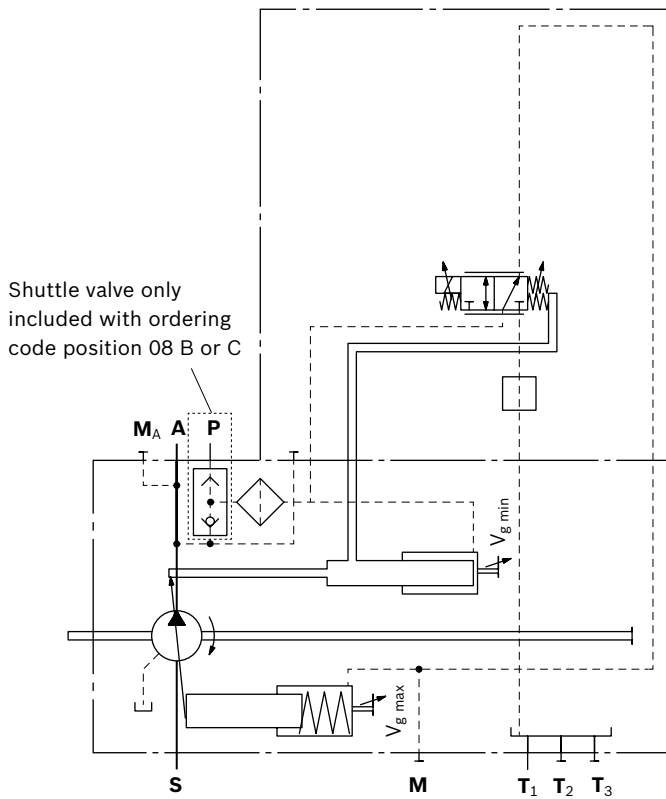

**H3 – Stroke control, hydraulic-proportional, pilot pressure (negative control)**

With pilot-pressure-related control, the pump displacement is adjusted in proportion to the pilot pressure applied at port **H3**.

Basic position without pilot signal is  $V_{g \max}$ . Mechanically depressurized basic position is  $V_{g \max}$  (see ordering code position 08, letter B).

- ▶ Adjustment from  $V_{g \max}$  to  $V_{g \min}$ : with increasing pilot pressure, the pump swivels to a smaller displacement.
- ▶ Setting range for beginning of control (at  $V_{g \max}$ ) 5 bar (75 psi) to 10 bar (145 psi), standard is 10 bar (145 psi). State beginning of control in plain text in the order.
- ▶ Maximum permissible pilot pressure  $p_{St \max} = 100$  bar (1450 psi)

The necessary control fluid is taken from the operating pressure or the external control pressure applied to port **P**. If the pump is to be adjusted from the basic position  $V_{g \min}$  or from a low operating pressure, port **P** must be supplied with an external control pressure of at least 30 bar (435 psi), maximum 50 bar (725 psi).

**Notice**  
If no external control pressure is applied to **P**, the version “Maximum swivel angle ( $V_{g \max}$ ), without external control pressure supply” is to be ordered (see ordering code position 08, letter A).

▼ **Circuit diagram H3**

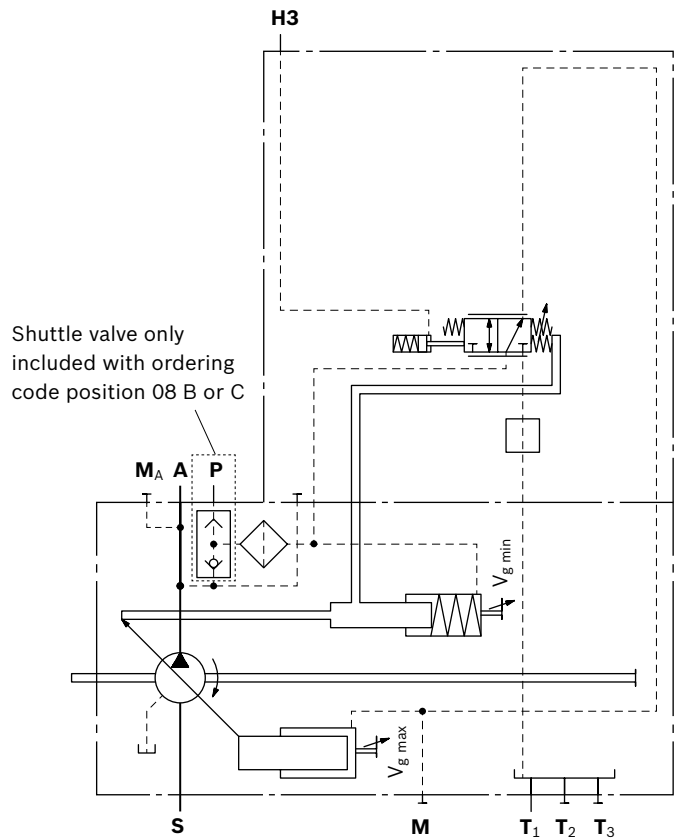

▼ **Characteristic H3 (negative)**

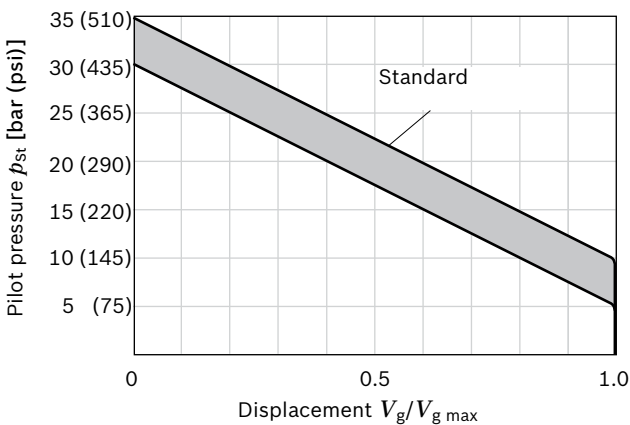

Increase in pilot pressure  $V_{g \max}$  to  $V_{g \min}$ :  $\Delta p = 25$  bar (365 psi)

When ordering, state in plain text:

- ▶ Beginning of control [bar (psi)] at  $V_{g \max}$



**H4 – Stroke control, hydraulic-proportional, pilot pressure (positive control)**

With pilot-pressure-related control, the pump displacement is adjusted in proportion to the pilot pressure applied at port **H4**.

Basic position without pilot signal is  $V_{g \min}$ . Mechanically depressurized basic position is  $V_{g \min}$  (see ordering code position 08, letter C).

- ▶ Adjustment from  $V_{g \min}$  to  $V_{g \max}$ ; with increasing pilot pressure the pump swivels to a larger displacement.
- ▶ Setting range for beginning of control (at  $V_{g \min}$ ) 5 bar (75 psi) to 10 bar (145 psi), standard is 10 bar (145 psi). State beginning of control in plain text in the order.
- ▶ Maximum permissible pilot pressure  $p_{St \max} = 100$  bar (1450 psi)

The necessary control fluid is taken from the operating pressure or the external control pressure applied to port **P**. If the pump is to be adjusted from the basic position  $V_{g \min}$  or from a low operating pressure, port **P** must be supplied with an external control pressure of at least 30 bar (435 psi), maximum 50 bar (725 psi).

**Notice**

If no external control pressure is applied to **P**, the version “Maximum swivel angle ( $V_{g \max}$ ), without external control pressure supply” is to be ordered (see ordering code position 08, letter A).

▼ **Characteristic H4 (positive)**

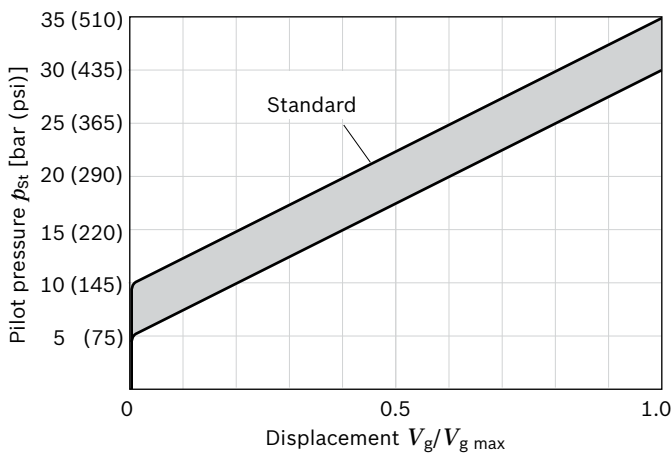

Increase in pilot pressure  $V_{g \min}$  to  $V_{g \max}$ :  $\Delta p = 25$  bar (365 psi)

When ordering, state in plain text:

- ▶ Beginning of control [bar (psi)] at  $V_{g \min}$

▼ **Circuit diagram H4**

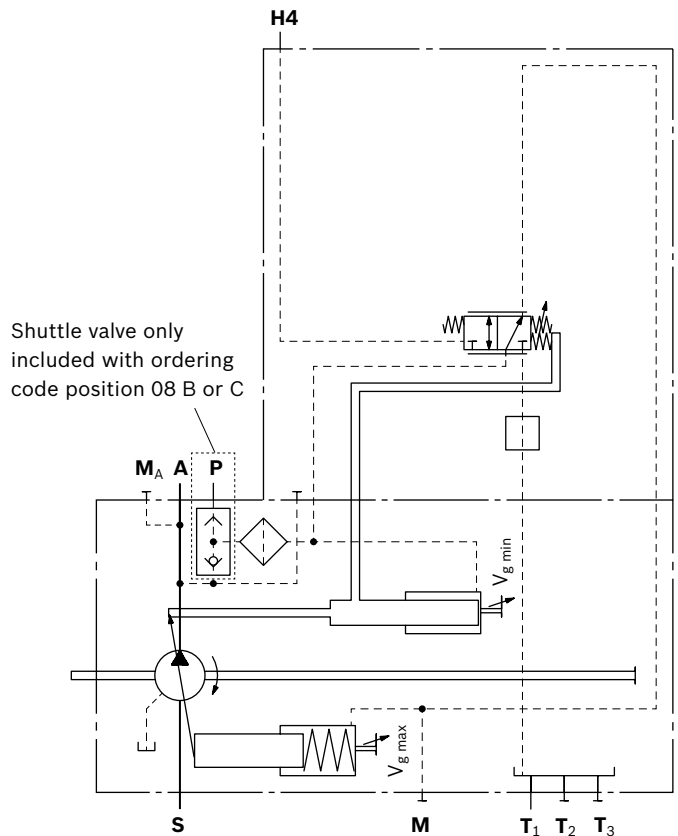

**Notice!**

The spring feedback in the controller is not a security device. The controller can stick in an undefined position due to internal contamination (contaminated hydraulic fluid, abrasion or residual contamination from system components). As a result, the flow of the axial piston unit will no longer respond correctly to the operator's commands. Check whether the application on your machine requires additional safety measures, in order to bring the driven consumer into a safe position (immediate stop). If necessary, make sure that these are properly implemented.

## Pressure control

### DR – Pressure controller with one-sided swiveling, fixed setting

The pressure controller limits the maximum pressure at the pump outlet within the control range of the variable pump. The variable pump only supplies as much hydraulic fluid as is required by the consumers. If the operating pressure exceeds the pressure setting at the pressure valve, the pump will regulate to a smaller displacement to reduce the control differential.

- ▶ Initial position in depressurized state:  $V_{g \max}$
- ▶ Setting range for beginning of control 50 bar (725 psi) to 350 bar (5100 psi), 350 bar (5100 psi) is standard.

### ▼ Characteristic curve DR

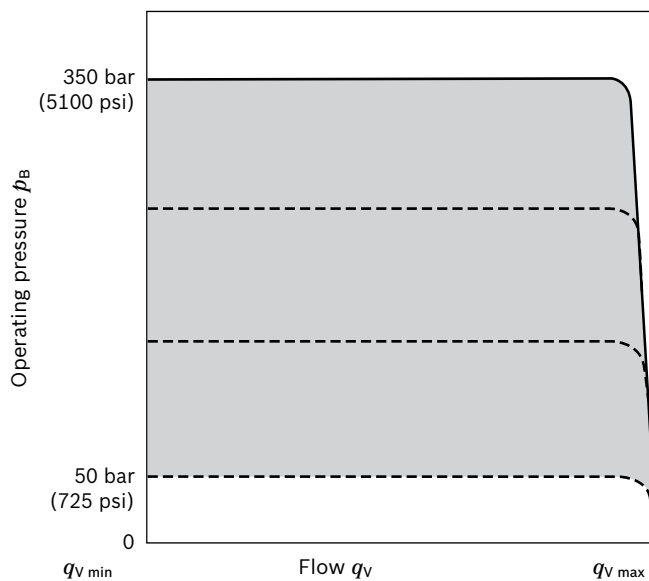

### Hydraulic $V_{g \min}$ stop

The hydraulic  $V_{g \min}$  stop opens the valve outlet to the case drain chamber when a minimum position is reached, damping the controller and reducing overshoot. This can cause a connection from high pressure or external control pressure via the controller and the hydraulic  $V_{g \min}$  stop to the case drain chamber.

When ordering, state in plain text:

- ▶ Pressure setting  $p$  [bar (psi)] at pressure controller DR

### ▼ Circuit diagram DR

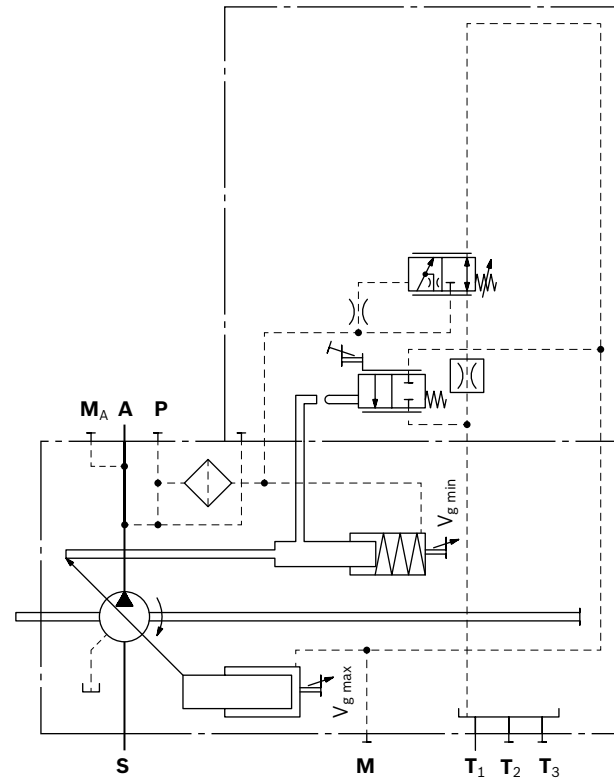

**DRS0 – Pressure control with load sensing**

The load sensing controller works as a load-pressure controlled flow controller and adjusts the displacement of the pump to the volume required by the consumer.

The flow of the pump is then dependent on the cross section of the external metering orifice (1), which is located between the pump and the consumer. Below the setting of the pressure controller and within the control range of the pump, the flow is not dependent on the load pressure.

The metering orifice is usually a separately located load sensing directional valve (control block). The position of the directional valve spool determines the opening cross-section of the metering orifice and thus the flow of the pump.

The load sensing controller compares pressure before and after the sensing orifice and keeps the pressure drop (differential pressure  $\Delta p$ ) across the orifice – and therefore the flow – constant.

If the differential pressure  $\Delta p$  at the measuring orifice rises, the pump is swiveled back (toward  $V_{g \min}$ ). If the differential pressure  $\Delta p$  drops, the pump is swiveled out (toward  $V_{g \max}$ ) until equilibrium at the measuring orifice is restored.

$$\Delta p_{\text{measuring orifice}} = p_{\text{pump}} - p_{\text{consumer}}$$

- ▶ Setting range for  $\Delta p$  14 bar (200 psi) to 30 bar (435 psi) (please state in plain text)
- ▶ Standard adjustment 14 bar (200 psi)

The stand-by pressure in zero stroke operation (metering orifice closed) is slightly higher than the  $\Delta p$  setting.

▼ **Characteristic DRS0**

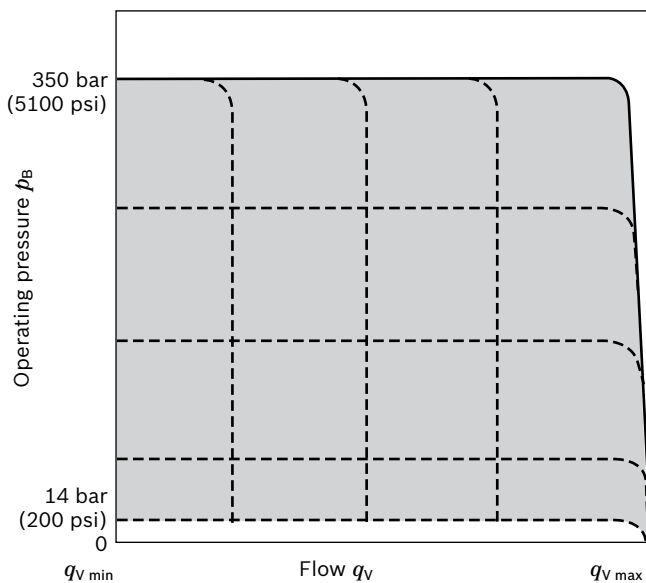

**Hydraulic  $V_{g \min}$  stop**

The hydraulic  $V_{g \min}$  stop opens the valve outlet to the case drain chamber when a minimum position is reached, damping the controller and reducing overshoot. This can cause a connection from high pressure or external control pressure via the controller and the hydraulic  $V_{g \min}$  stop to the case drain chamber.

When ordering, state in plain text:

- ▶ Pressure setting  $p$  [bar (psi)] at pressure controller DR
- ▶ Differential pressure  $\Delta p$  [bar (psi)] at load sensing controller S0

▼ **Circuit diagram DRS0**

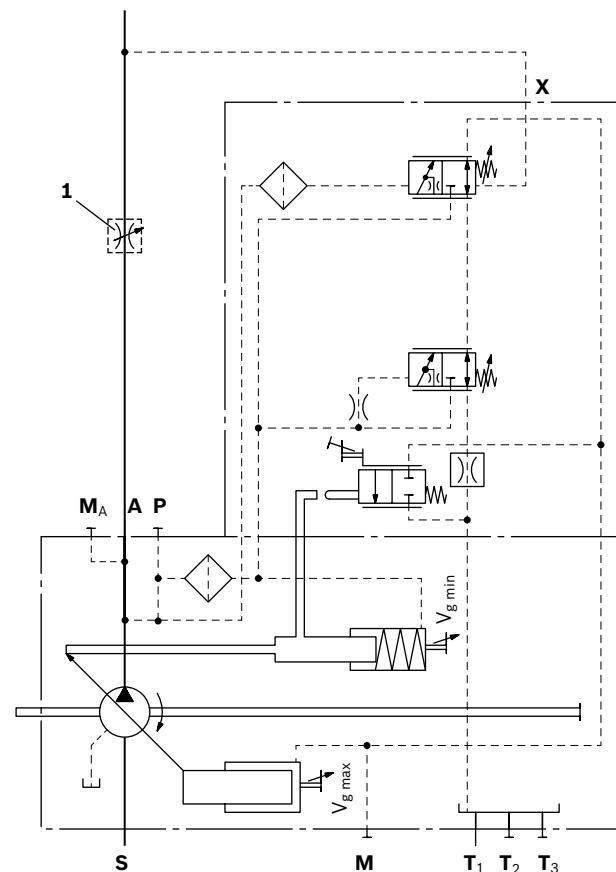

1 The metering orifice (control block) is not included in the scope of delivery.

**DG – Pressure control with one-sided deflection, hydraulically remote controlled (positive control)**

The remote controlled pressure control has a fixed-setting  $\Delta p$  value. A separately connected pressure relief valve at port **X (1)** enables the pressure control to be remotely controlled.

- ▶ Setting range  $\Delta p$  14 bar (200 psi) to 25 bar (365 psi)
- ▶ Recommended value 20 bar (290 psi) (standard)
- ▶ Control volume at **X**: about 1.6 l/min (0.42 gpm) (static) at  $\Delta p$  20 bar (290 psi)

In addition a separately configured 2/2 directional valve (**2**) can be operated to start the pump with low operating pressure (standby pressure).

Both functions can be used individually or in combination (see circuit diagram).

The external valves are not included in the scope of supply.

As a separate pressure relief valve (**1**) we recommend:

- ▶ For DBD.6, see data sheet 25402

**Hydraulic  $V_{g\ min}$  stop**

The hydraulic  $V_{g\ min}$  stop opens the valve outlet to the case drain chamber when a minimum position is reached, damping the controller and reducing overshoot. This can cause a connection from high pressure or external control pressure via the controller and the hydraulic  $V_{g\ min}$  stop to the case drain chamber.

- ▶ Operating pressure  $p$  in bar (psi) (test pressure for DG)
- ▶ Differential pressure  $\Delta p$  in bar (psi)
- ▶ Drive speed  $n$  in rpm
- ▶ Maximum flow  $qV_{\ max}$  in l/min (gpm)

Note about setting of the remote control pressure control: The setting value for the external pressure relief valve plus the differential pressure value at the pressure control valve determines the level of pressure control.

**Example:**

- ▶ external pressure relief valve 330 bar (4800 psi)
- ▶ Differential pressure at pressure control valve 20 bar (290 psi)
- ▶ resulting pressure control with 330 + 20 = 350 bar (4810 + 290 = 5100 psi)

▼ **Characteristic DG**

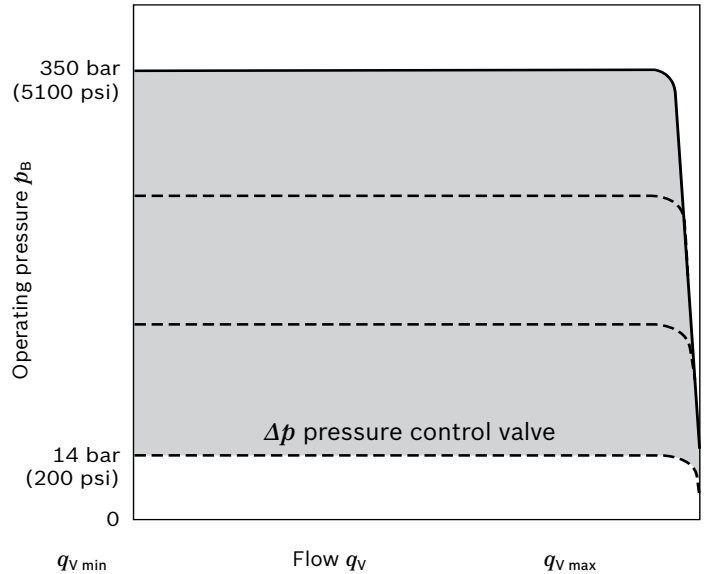

For function and description of pressure control DR, see page 22

▼ **Circuit diagram DG**

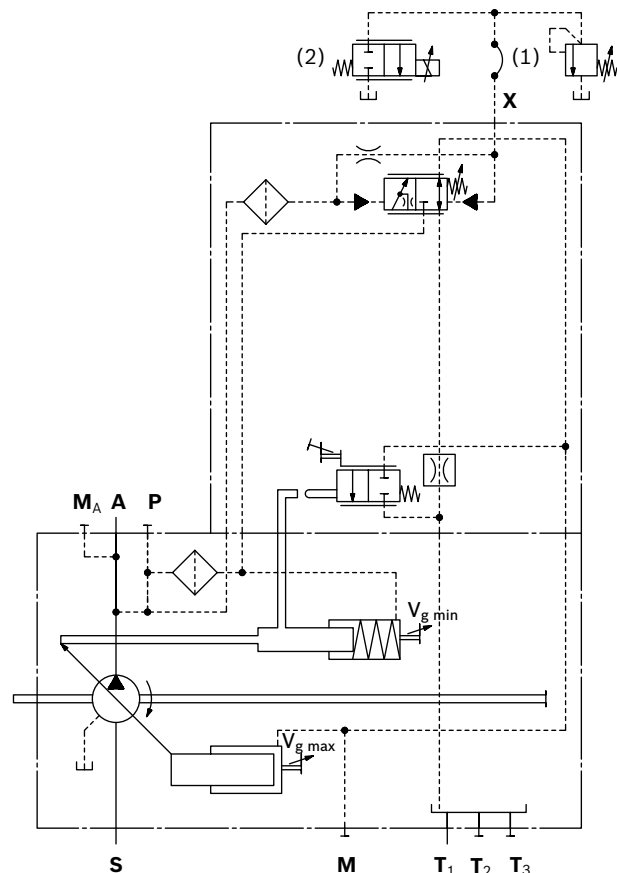

- 1 Pressure-relief valve (not included in the scope of supply)
- 2 2/2 directional valve (not included in the scope of supply)

**D2 – Proportional pressure control with one-side swiveling, electric override (M2 with two-side swiveling) (positive control)**

The pressure controller keeps the pressure in a hydraulic system constant within its control range even under varying flow conditions. The variable pump only supplies as much hydraulic fluid as is required by the consumers.

If the operating pressure exceeds the setting at the integrated pressure control valve, the pump is automatically swiveled back to reduce the control differential.

- ▶ Initial position in depressurized state:  $V_{g \max}$
- ▶ Pressure controller basic setting: 32 bar (470 psi)/300 mA

The basic setting of the pressure controller can be overridden. The pressure control value is proportional to the electrical current acting on the solenoids of the pressure reducing valve.

- ▶ Pressure setting overridden:  
32 bar (470 psi)/300 mA to 350 bar (5100 psi)/750 mA
- ▶ Auxiliary pressure for controlling D2 at port **Y**:  
 $p_{\min} = 40$  bar;  $p_{\max} = 50$  bar.  
Port **X** acts solely as a measuring port ( $p_{\max} 50$  bar).  
Pressurization leads to an impermissible increase in pressure.

**Notice**

Applying current above the limit of 750 mA to the proportional solenoid results in an impermissible increase in pressure.

Make sure that currents above the permissible limit are not applied to the proportional solenoid.

▼ **Characteristic D2**

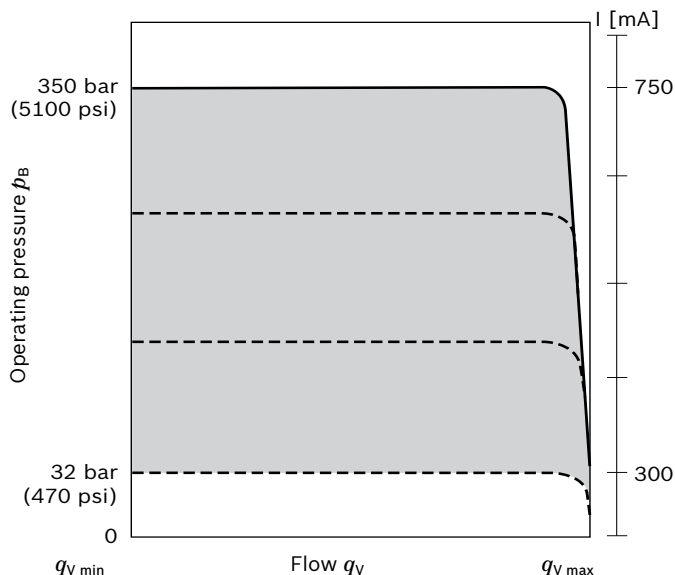

Technical data, solenoid	D2	D2
Voltage	24 V	24 V
Control current		
Beginning of control at $V_{g \min}$		300 mA
End of control at $V_{g \max}$		750 mA
Current limit	750 mA	750 mA
Nominal resistance (at 20 °C (68 °F))	12 $\Omega$	12 $\Omega$
Dither frequency	200 Hz	200 Hz
Duty cycle	100%	100 %
Type of protection: see connector version page 63		

The following electronic controllers and amplifiers are available for controlling the proportional solenoids:

BODAS RC controllers Series	Data sheet
20	95200
21	95201
22	95202
30	95203
and application software	95230
Analog amplifier RA	95230

▼ **Circuit diagram D2**

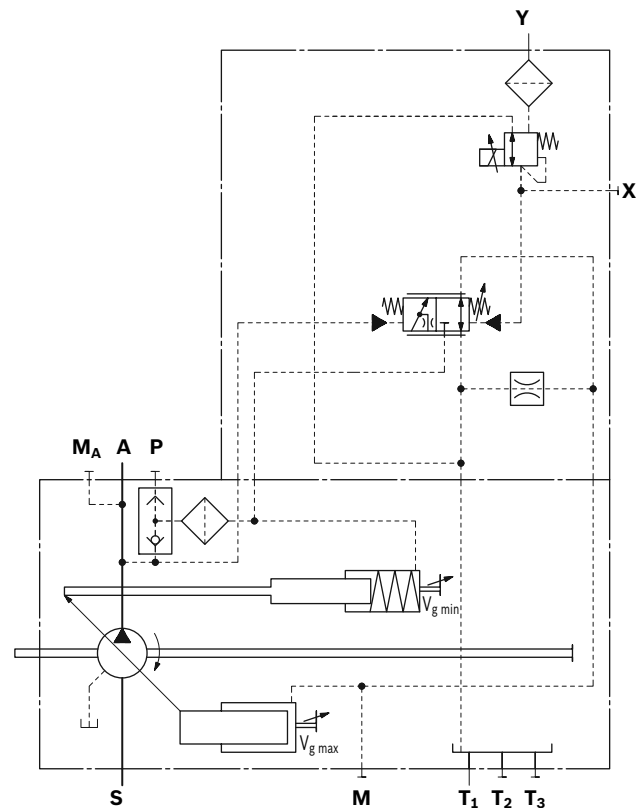

**Dimensions size 110**

**LRDRS0 – Power controller with pressure controller, load sensing and with electric swivel angle sensor**

Without charge pump, clockwise rotation

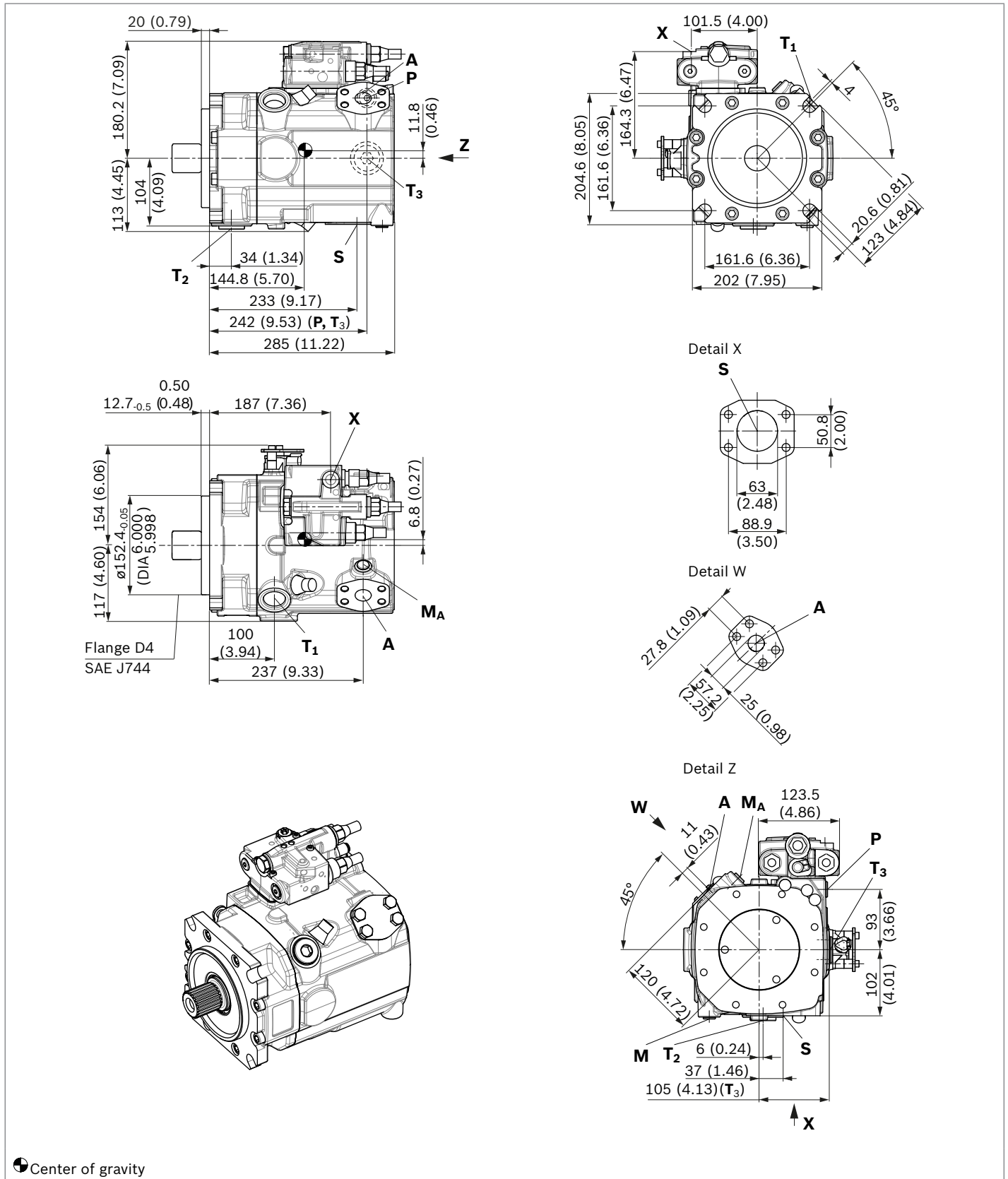

## ▼ Splined shaft DIN 5480

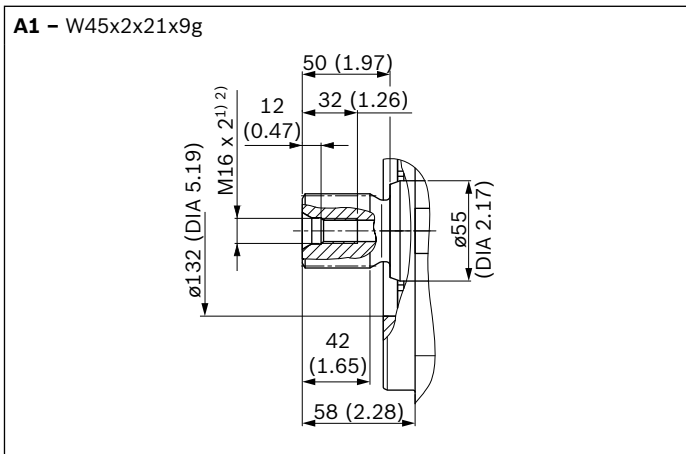

Ports – version “M” metric		Standard	Size <sup>2)</sup>	$p_{\max \text{ abs}}$ [bar (psi)] <sup>3)</sup>	State <sup>7)</sup>
<b>A</b>	Service line	SAE J518 <sup>4)</sup>	1 in	420 (6100)	O
	Fastening thread	DIN 13	M12 × 1.75; 18 deep		
<b>S</b>	Suction port (without charge pump)	SAE J518 <sup>4)</sup>	2 1/2 in	30 (435)	O
	Fastening thread	DIN 13	M12 × 1.75; 18 deep		
<b>T<sub>1</sub></b>	Drain port	ISO 6149 <sup>5)</sup>	M33 × 2; 19 deep	10 (145)	O <sup>6)</sup>
<b>T<sub>2</sub></b>	Drain port	ISO 6149 <sup>5)</sup>	M33 × 2; 19 deep	10 (145)	X <sup>6)</sup>
<b>T<sub>3</sub></b>	Drain port	ISO 6149 <sup>5)</sup>	M33 × 2; 19 deep	10 (145)	X <sup>6)</sup>
<b>CR</b>	Pilot signal (CR only)	ISO 6149	M14 × 1.5; 11.5 deep	420 (6100)	O
<b>PR</b>	Pilot signal (PR only)	ISO 6149	M14 × 1.5; 11.5 deep	420 (6100)	O
<b>H3, H4</b>	Pilot signal (H3 and H4 only)	ISO 6149	M14 × 1.5; 11.5 deep	100 (1450)	O
<b>L5, L6</b>	Override power controller (only with L5 and L6)	ISO 6149	M14 × 1.5; 11.5 deep	100 (1450)	O
<b>X</b>	Pilot signal (S0 and DG only)	ISO 6149 <sup>5)</sup>	M14 × 1.5; 11.5 deep	420 (6100)	O
<b>M</b>	Measuring, control pressure	ISO 6149 <sup>5)</sup>	M14 × 1.5; 12 deep	420 (6100)	X
<b>M<sub>A</sub></b>	Measuring, pressure A	ISO 6149 <sup>5)</sup>	M14 × 1.5; 12 deep	420 (6100)	X
<b>P</b>	External control pressure (Ordering code position 8 version B or C = with external control pressure supply)	ISO 6149 <sup>5)</sup>	M14 × 1.5; 11.5 deep	50 (725)	O
	Port <b>P</b> is without function (Ordering code position 8 version A = without external control pressure supply)	ISO 6149 <sup>5)</sup>	M18 × 1.5; 14.5 deep	420 (6100)	X

- Center bore according to DIN 332 (thread according to DIN 13)
- Observe the instructions in the operating instructions concerning the maximum tightening torques.
- Depending on the application, momentary pressure peaks can occur. Keep this in mind when selecting measuring devices and fittings.
- Metric fastening thread is a deviation from standard.

- The countersink can be deeper than as specified in the standard.
- Depending on installation position, T<sub>1</sub>, T<sub>2</sub> or T<sub>3</sub> must be connected (see also Installation instructions on pages 64 and 65).
- O = Must be connected (plugged when delivered)  
X = Plugged (in normal operation)

▼ **Splined shaft SAE J744**

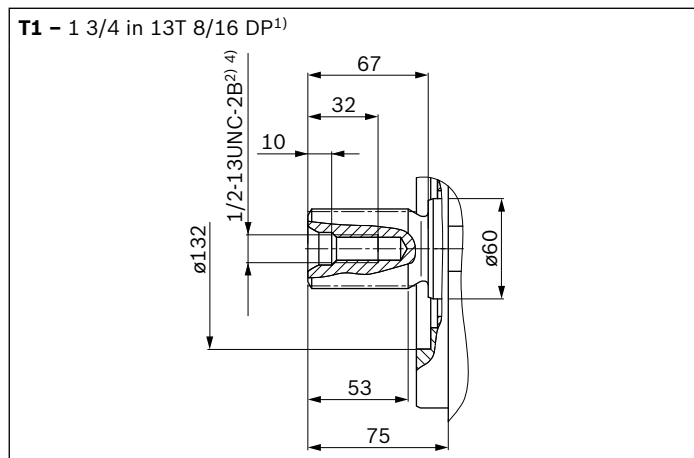

Ports - version "A" SAE	Standard	Size <sup>3)</sup>	$p_{\max \text{ abs}}$ [bar (psi)] <sup>4)</sup>	State <sup>7)</sup>
<b>A</b> Service line Fastening thread	SAE J518 ASME B1.1	1 in 7/16-14UNC-2B; 19 (0.75) deep	420 (6100)	O
<b>S</b> Suction port (without charge pump) Fastening thread	SAE J518 ASME B1.1	2 1/2 in 1/2-13UNC-2B; 19 (0.75) deep	30 (435)	O
<b>T<sub>1</sub></b> Drain port	ISO 11926 <sup>5)</sup>	1 5/16UNF-2B; 20 (0.79) deep	10 (145)	O <sup>6)</sup>
<b>T<sub>2</sub></b> Drain port	ISO 11926 <sup>5)</sup>	1 5/16UNF-2B; 20 (0.79) deep	10 (145)	X <sup>6)</sup>
<b>T<sub>3</sub></b> Drain port	ISO 11926 <sup>5)</sup>	1 5/16UNF-2B; 20 (0.79) deep	10 (145)	X <sup>6)</sup>
<b>CR</b> Pilot signal (CR only)	ISO 11926	9/16-18 UNF-2B; 13 (0.51) deep	420 (6100)	O
<b>PR</b> Pilot signal (PR only)	ISO 11926	9/16-18 UNF-2B; 13 (0.51) deep	420 (6100)	O
<b>H3, H4</b> Pilot signal (H3 and H4 only)	ISO 11926	9/16-18 UNF-2B; 13 (0.51) deep	100 (1450)	O
<b>L5, L6</b> Override power controller (only with L5 and L6)	ISO 11926	9/16-18 UNF-2B; 13 (0.51) deep	100 (1450)	O
<b>X</b> Pilot signal (S0 and DG only)	ISO 11926 <sup>5)</sup>	9/16-18 UNF-2B; 13 (0.51) deep	420 (6100)	O
<b>M</b> Measuring, control pressure	ISO 11926 <sup>5)</sup>	9/16-18 UNF-2B; 13 (0.51) deep	420 (6100)	X
<b>M<sub>A</sub></b> Measuring, pressure A	ISO 11926 <sup>5)</sup>	9/16-18 UNF-2B; 13 (0.51) deep	420 (6100)	X
<b>P</b> External control pressure (Ordering code position 8 version B or C = with external control pressure supply)	ISO 11926 <sup>5)</sup>	9/16-18 UNF-2B; 13 (0.51) deep	50 (725)	O
Port <b>P</b> is without function (Ordering code position 8 version A = without external control pressure supply)	ISO 11926 <sup>5)</sup>	3/4-16 UNF-2B; 12.6 (0.50) deep	420 (6100)	X

1) Involute spline according to ANSI B92.1a, 30° pressure angle, flat root, side fit, tolerance class 5  
 2) Centering bore according to ASME B1.1  
 3) Observe the instructions in the operating instructions concerning the maximum tightening torques.  
 4) Depending on the application, momentary pressure peaks can occur. Keep this in mind when selecting measuring devices and fittings.

5) The countersink can be deeper than as specified in the standard.  
 6) Depending on installation position, T<sub>1</sub>, T<sub>2</sub> or T<sub>3</sub> must be connected (see also Installation instructions on pages 64 and 65).  
 7) O = Must be connected (plugged when delivered)  
 X = Plugged (in normal operation)



▼ **LR** – Power controller, fixed setting

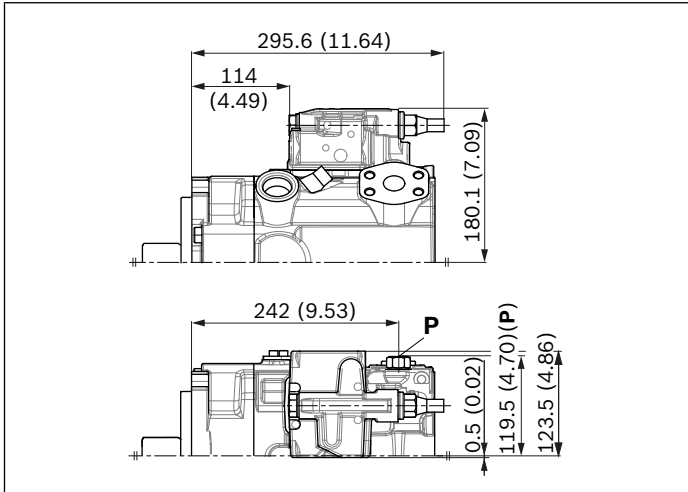

▼ **L3/L4** – Power controller, electric-proportional override

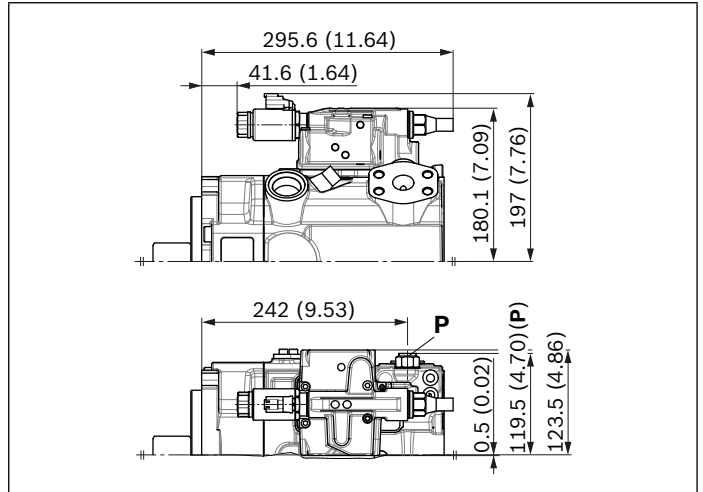

▼ **L5/L6** – Power controller, hydraulic-proportional override

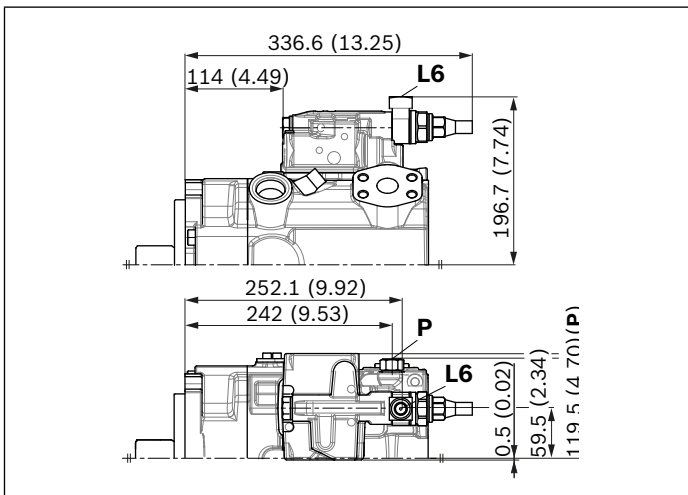

▼ **CR** – Power controller, hydraulic-proportional override, high pressure, with stop

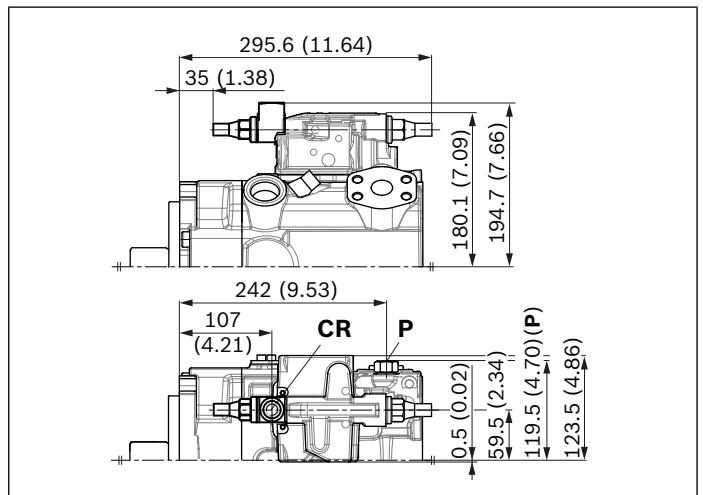

▼ **PR** – Power controller, hydraulic-proportional override, high pressure, without stop

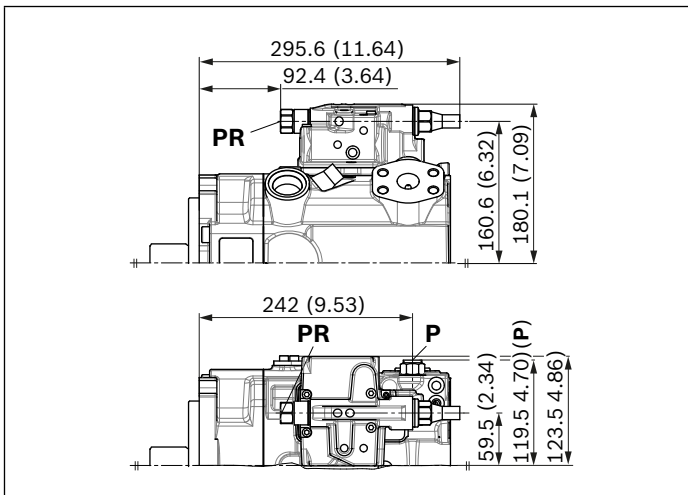

▼ **E1/E2** – Stroke control electric-proportional

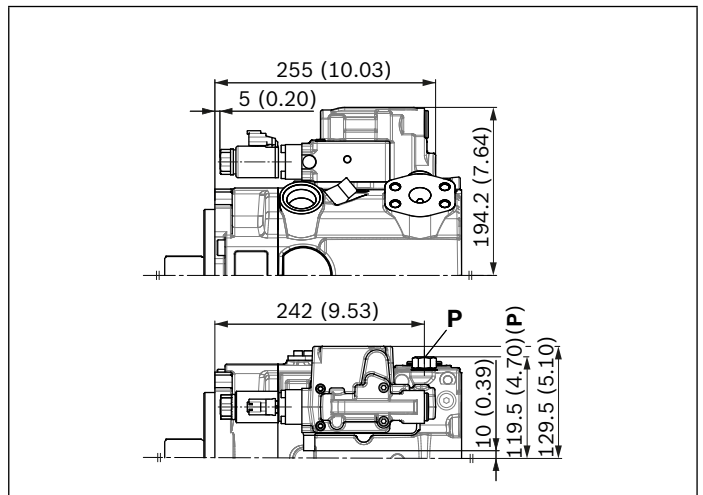

**Notice**

All controllers described with shuttle valve in **P** (some contrary to standard according to ordering code position 08)

▼ **H3/H4** – Stroke control, hydraulic-proportional, pilot pressure

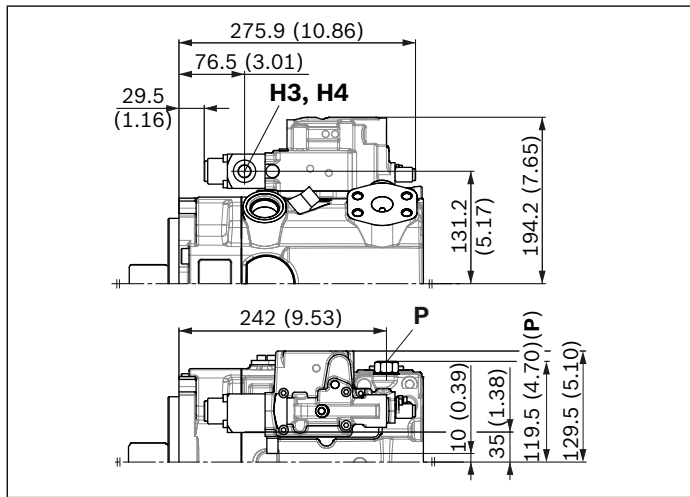

▼ **DR** – Pressure controller, fixed setting

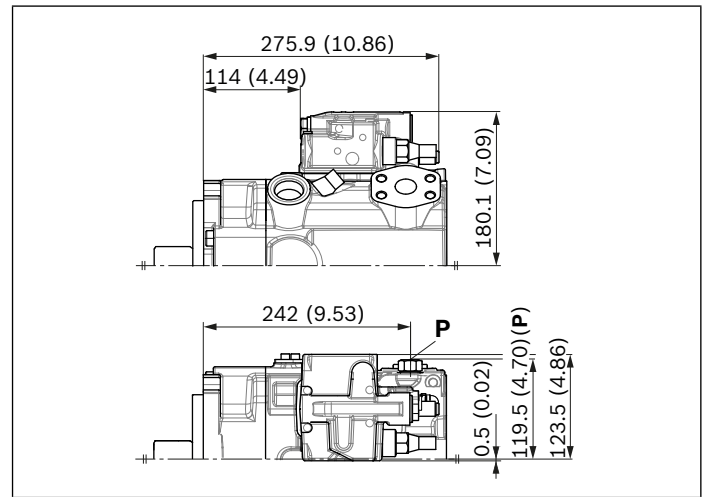

▼ **LRDRS0** – Power controller with pressure controller and load sensing, fixed setting

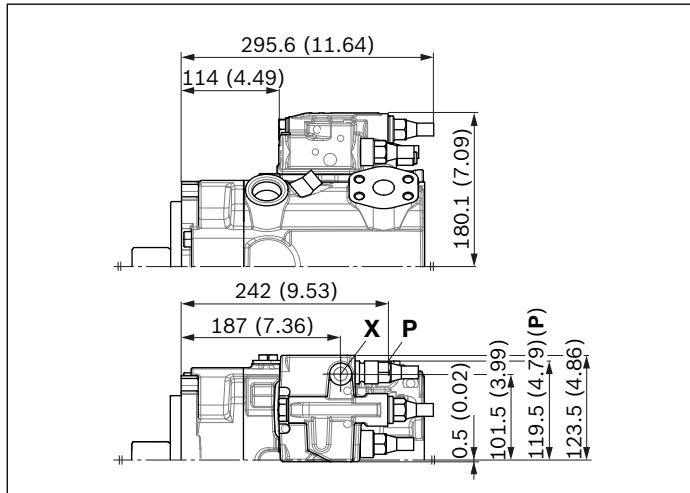

▼ **DG** – Pressure controller, hydraulic, remote controlled

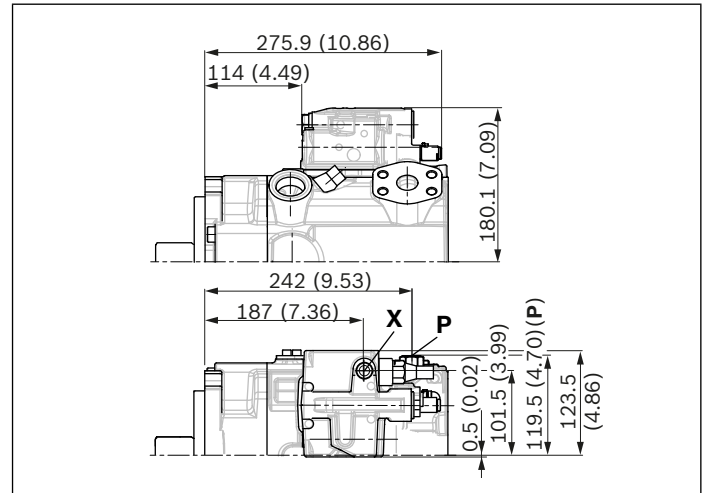

**Notice**

All controllers described with shuttle valve in **P** (some contrary to standard as per ordering code position 08)

**Dimensions size 145**

**LRDRS0 – Power controller with pressure controller, load sensing and with electric swivel angle sensor**  
 Without charge pump, clockwise rotation

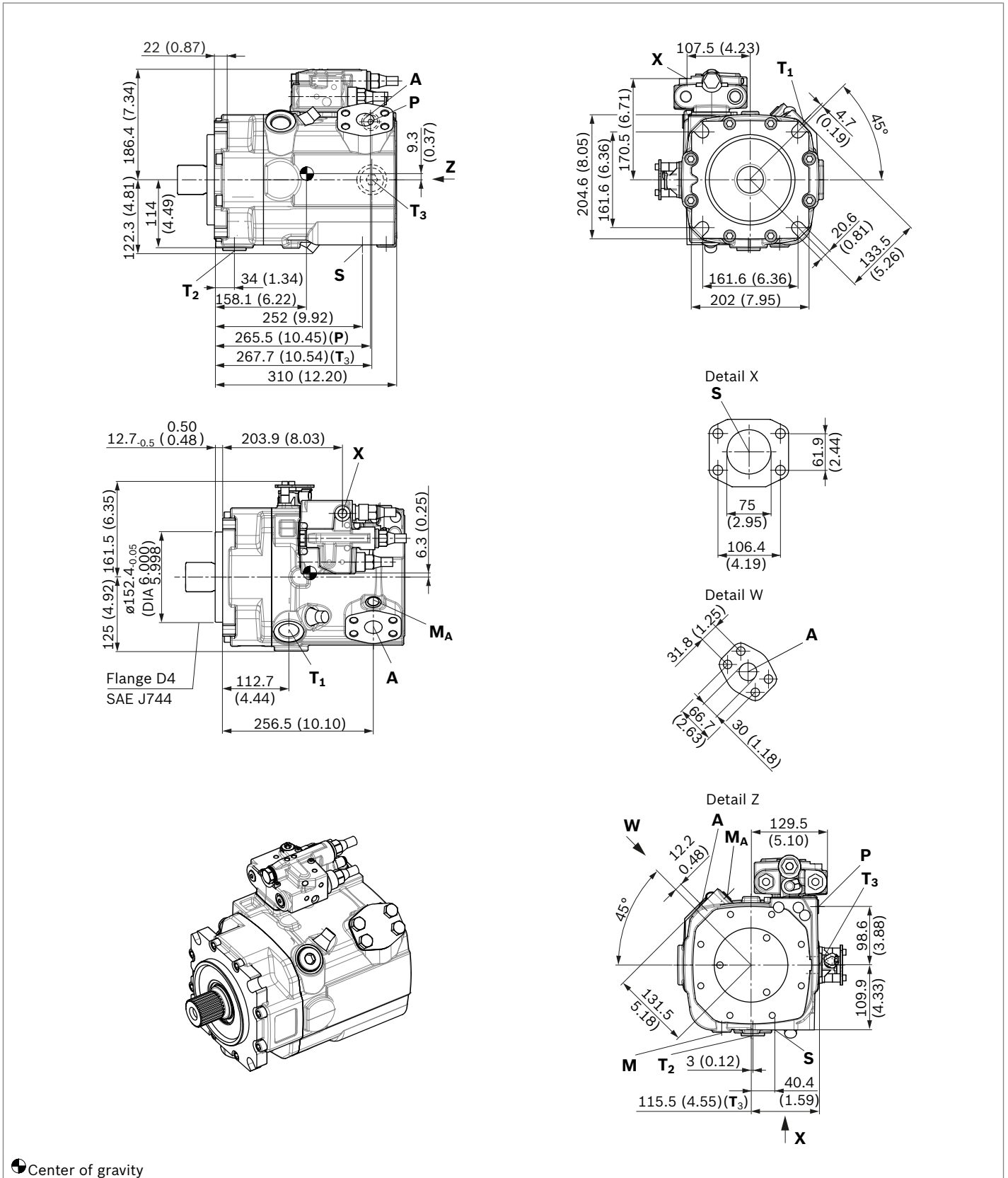

**LRDRS0 – Power controller with pressure controller, load sensing and with electric swivel angle sensor**

With charge pump, clockwise rotation

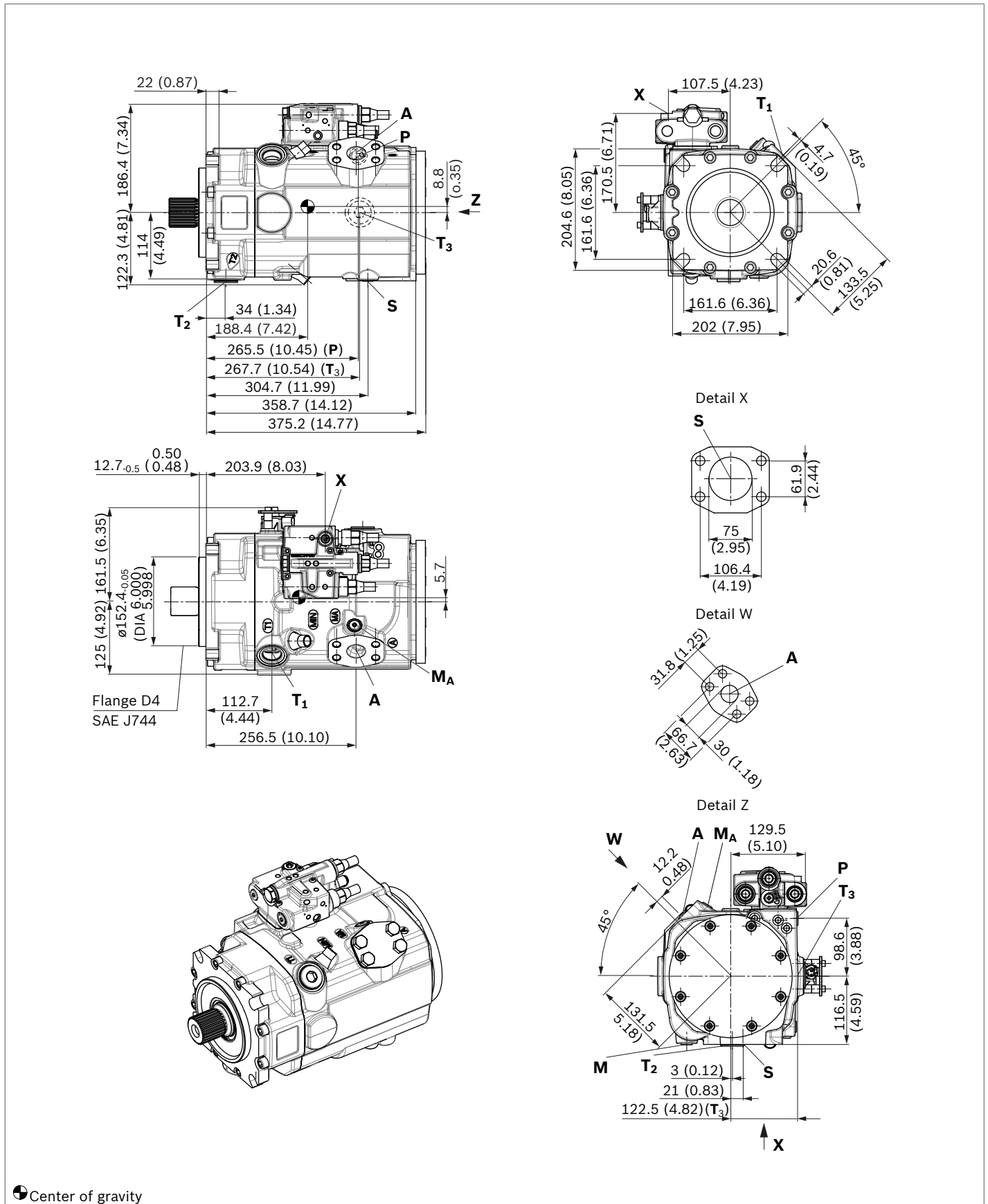

**L450 – Power controller electrically proportional, load sensing and with electric swivel angle sensor**

Mounting flange G3 according to SAE J617; 409-12; without charge pump

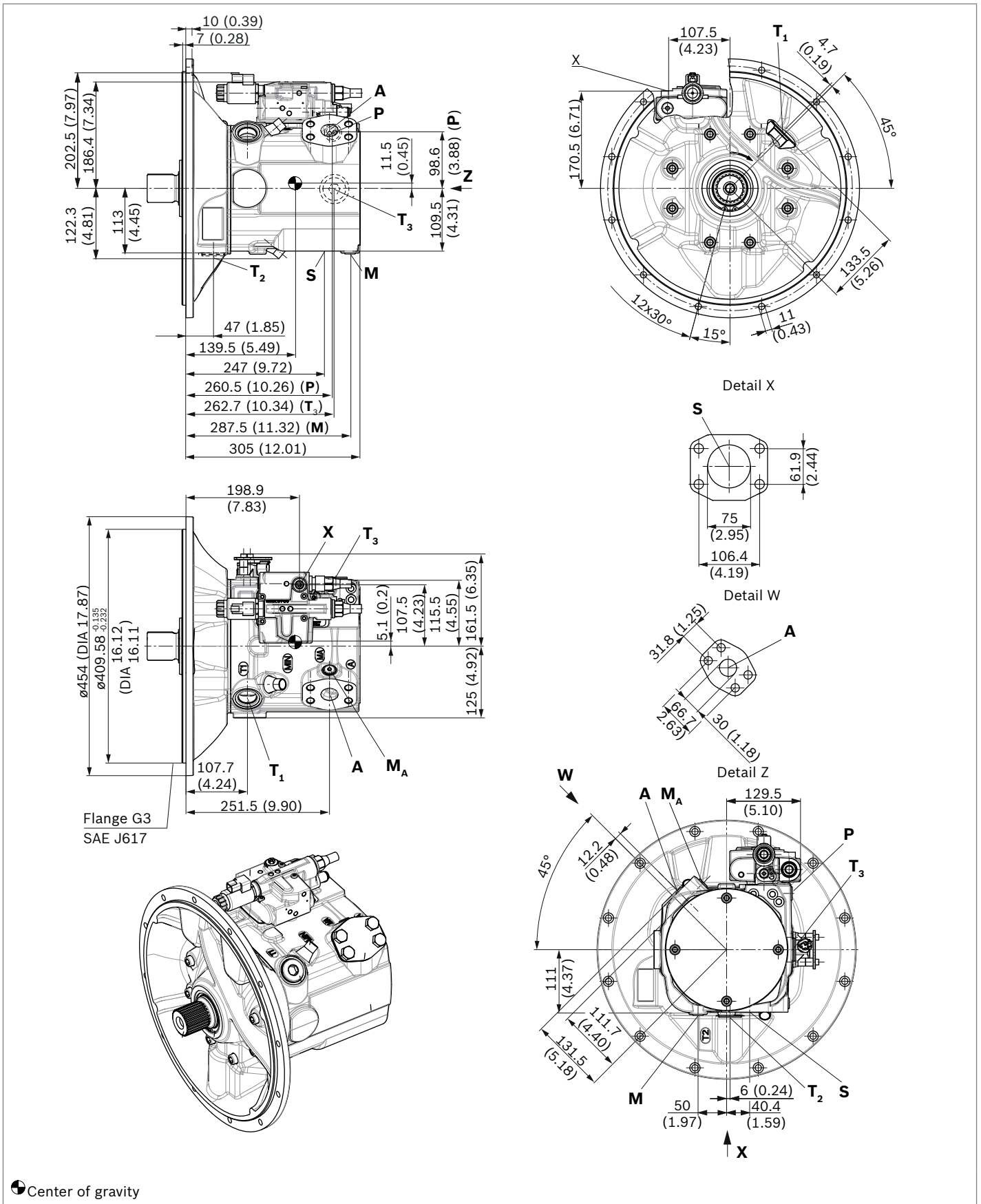

▼ **Splined shaft SAE J744**

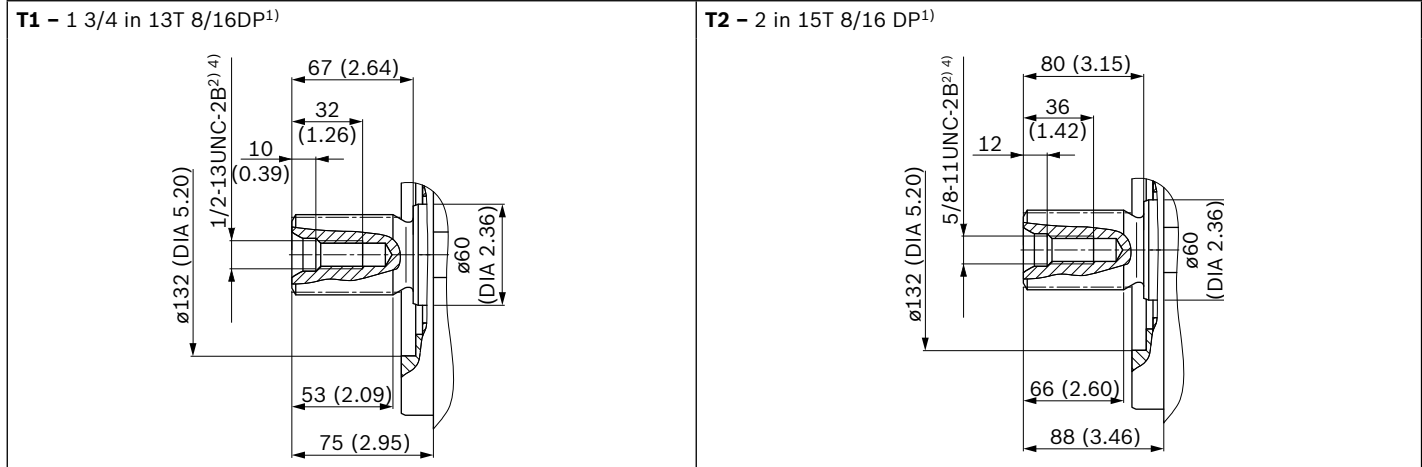

▼ **Splined shaft DIN 5480**

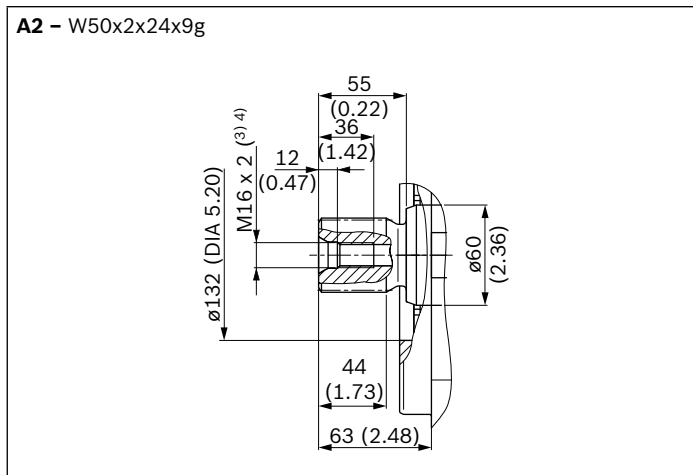

- 1) Involute spline according to ANSI B92.1a, 30° pressure angle, flat root, side fit, tolerance class 5
- 2) Thread according to ASME B1.1
- 3) Center bore according to DIN 332 (thread according to DIN 13)
- 4) Observe the instructions in the operating instructions concerning the maximum tightening torques.

Ports – version “M” metric		Standard	Size <sup>4)</sup>	$p_{\max \text{ abs}}$ [bar (psi)] <sup>5)</sup>	State <sup>9)</sup>
<b>A</b>	Service line	SAE J518 <sup>6)</sup>	1 1/4 in	420 (6100)	O
	Fastening thread	DIN 13	M14 × 2; 22 (0.87) deep		
<b>S</b>	Suction port (without charge pump)	SAE J518 <sup>6)</sup>	3 in	30 (435)	O
	Fastening thread	DIN 13	M16 × 2; 24 (0.94) deep		
<b>S</b>	Suction port (with charge pump)	SAE J518 <sup>6)</sup>	3 in	2 (30)	O
	Fastening thread	DIN 13	M16 × 2; 24 (0.94) deep		
<b>T<sub>1</sub></b>	Drain port	ISO 6149 <sup>7)</sup>	M33 × 2; 19 (0.75) deep	10 (145)	O <sup>8)</sup>
<b>T<sub>2</sub></b>	Drain port	ISO 6149 <sup>7)</sup>	M33 × 2; 19 (0.75) deep	10 (145)	X <sup>8)</sup>
<b>T<sub>3</sub></b>	Drain port	ISO 6149 <sup>7)</sup>	M33 × 2; 19 (0.75) deep	10 (145)	X <sup>8)</sup>
<b>CR</b>	Pilot signal (CR only)	ISO 6149	M14 × 1.5; 11.5 (0.45) deep	420 (6100)	O
<b>PR</b>	Pilot signal (PR only)	ISO 6149	M14 × 1.5; 11.5 (0.45) deep	420 (6100)	O
<b>H3, H4</b>	Pilot signal (H3 and H4 only)	ISO 6149	M14 × 1.5; 11.5 (0.45) deep	100 (1450)	O
<b>L5, L6</b>	Override power controller (only with L5 and L6)	ISO 6149	M14 × 1.5; 11.5 (0.45) deep	100 (1450)	O
<b>X</b>	Pilot signal (S0 and DG only)	ISO 6149 <sup>7)</sup>	M14 × 1.5; 11.5 (0.45) deep	420 (6100)	O
<b>M</b>	Measuring, control pressure	ISO 6149 <sup>7)</sup>	M14 × 1.5; 12 (0.47) deep	420 (6100)	X
<b>M<sub>A</sub></b>	Measuring, pressure A	ISO 6149 <sup>7)</sup>	M14 × 1.5; 12 (0.47) deep	420 (6100)	X
<b>P</b>	External control pressure (Ordering code position 8 version B or C = with external control pressure supply)	ISO 6149 <sup>7)</sup>	M14 × 1.5; 11.5 (0.45) deep	50 (725)	O
	Port <b>P</b> is without function (Ordering code position 8 version A = without external control pressure supply)	ISO 6149 <sup>7)</sup>	M18 × 1.5; 14.5 (0.57) deep	420 (6100)	X

Ports – version “A” SAE		Standard	Size <sup>4)</sup>	$p_{\max \text{ abs}}$ [bar (psi)] <sup>5)</sup>	State <sup>9)</sup>
<b>A</b>	Service line	SAE J518	1 1/4 in	420 (6100)	O
	Fastening thread	ASME B1.1	1/2-13 UNC-2B; 19 (0.75) deep		
<b>S</b>	Suction port (without charge pump)	SAE J518	3 in	30 (435)	O
	Fastening thread	ASME B1.1	5/8-11 UNC-2B; 24 (0.94) deep		
<b>S</b>	Suction port (with charge pump)	SAE J518	3 in	2 (30)	O
	Fastening thread	ASME B1.1	5/8-11 UNC-2B; 24 (0.94) deep		
<b>T<sub>1</sub></b>	Drain port	ISO 11926 <sup>7)</sup>	1 5/16 UNF-2B; 20 (0.79) deep	10 (145)	O <sup>8)</sup>
<b>T<sub>2</sub></b>	Drain port	ISO 11926 <sup>7)</sup>	1 5/16 UNF-2B; 20 (0.79) deep	10 (145)	X <sup>8)</sup>
<b>T<sub>3</sub></b>	Drain port	ISO 11926 <sup>7)</sup>	1 5/16 UNF-2B; 20 (0.79) deep	10 (145)	X <sup>8)</sup>
<b>CR</b>	Pilot signal (CR only)	ISO 11926	9/16-18 UNF-2B; 13 (0.51) deep	420 (6100)	O
<b>PR</b>	Pilot signal (PR only)	ISO 11926	9/16-18 UNF-2B; 13 (0.51) deep	420 (6100)	O
<b>H3, H4</b>	Pilot signal (H3 and H4 only)	ISO 11926	9/16-18 UNF-2B; 13 (0.51) deep	100 (1450)	O
<b>L5, L6</b>	Override power controller (only with L5 and L6)	ISO 11926	9/16-18 UNF-2B; 13 (0.51) deep	100 (1450)	O
<b>X</b>	Pilot signal (S0 and DG only)	ISO 11926 <sup>7)</sup>	9/16-18 UNF-2B; 13 (0.51) deep	420 (6100)	O
<b>M</b>	Measuring, control pressure	ISO 11926 <sup>7)</sup>	9/16-18 UNF-2B; 13 (0.51) deep	420 (6100)	X
<b>M<sub>A</sub></b>	Measuring, pressure A	ISO 11926 <sup>7)</sup>	9/16-18 UNF-2B; 13 (0.51) deep	420 (6100)	X
<b>P</b>	External control pressure (Ordering code position 8 version B or C = with external control pressure supply)	ISO 11926 <sup>7)</sup>	9/16-18 UNF-2B; 13 (0.51) deep	50 (725)	O
	Port <b>P</b> is without function (Ordering code position 8 version A = without external control pressure supply)	ISO 11926 <sup>7)</sup>	3/4-16 UNF-2B; 12.6 (0.50) deep	420 (6100)	X

5) Depending on the application, momentary pressure peaks can occur.  
Keep this in mind when selecting measuring devices and fittings.

6) Metric fastening thread is a deviation from standard.

7) The countersink can be deeper than as specified in the standard.

8) Depending on installation position, T<sub>1</sub>, T<sub>2</sub> or T<sub>3</sub> must be connected  
(see also Installation instructions on pages 64 and 65).

9) O = Must be connected (plugged when delivered)

X = Plugged (in normal operation)



▼ **LR** – Power controller, fixed setting

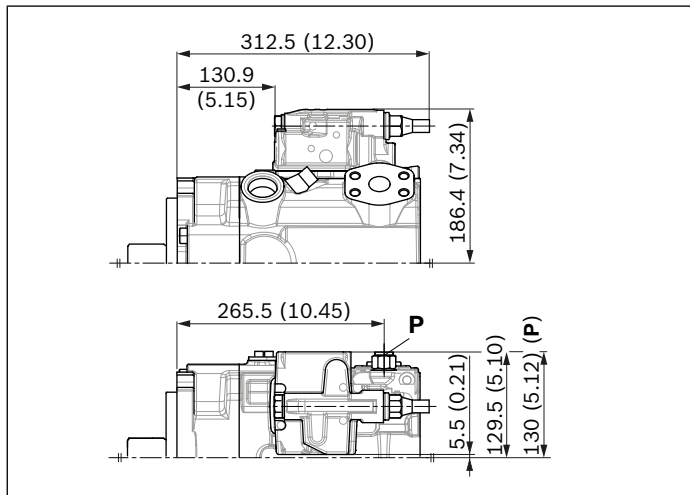

▼ **L3/L4** – Power controller, electric-proportional override

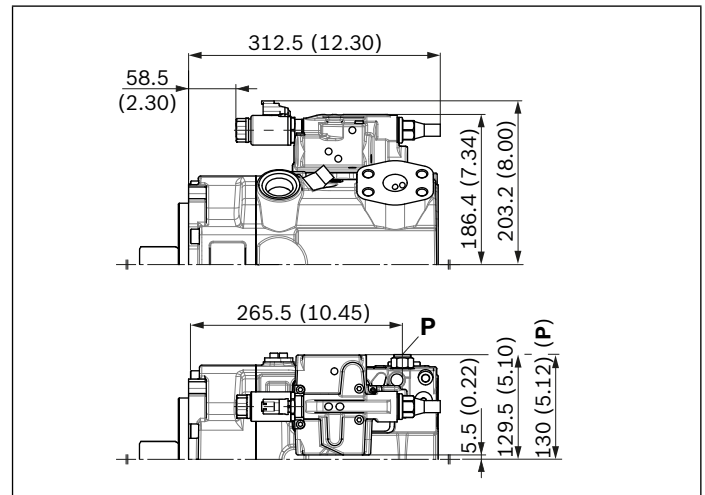

▼ **L5/L6** – Power controller, hydraulic override

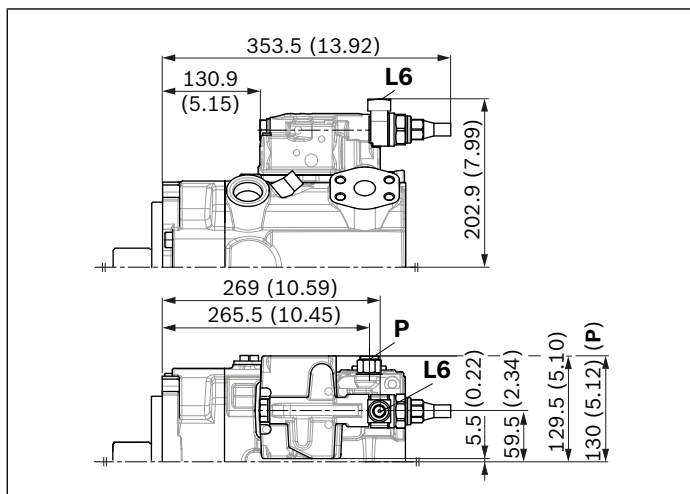

▼ **CR** – Power controller, hydraulic-proportional override, high pressure, with stop

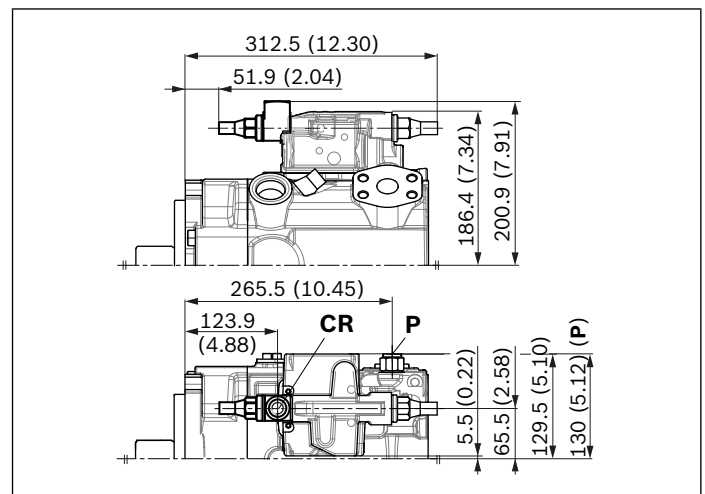

▼ **PR** – Power controller, hydraulic-proportional override, high pressure, without stop

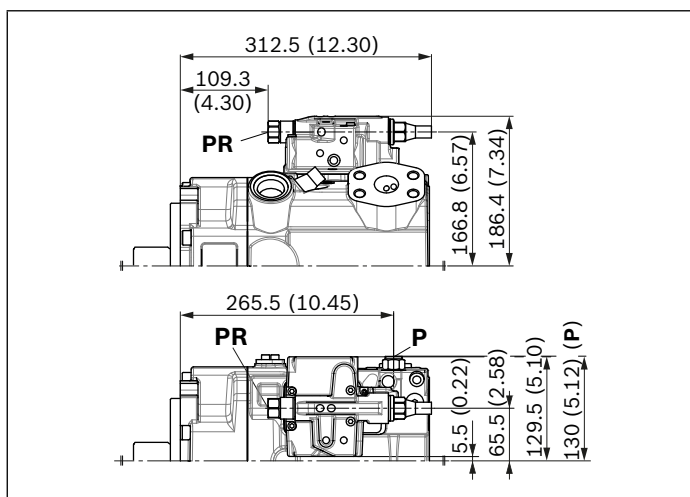

▼ **E1/E2** – Stroke control electric-proportional

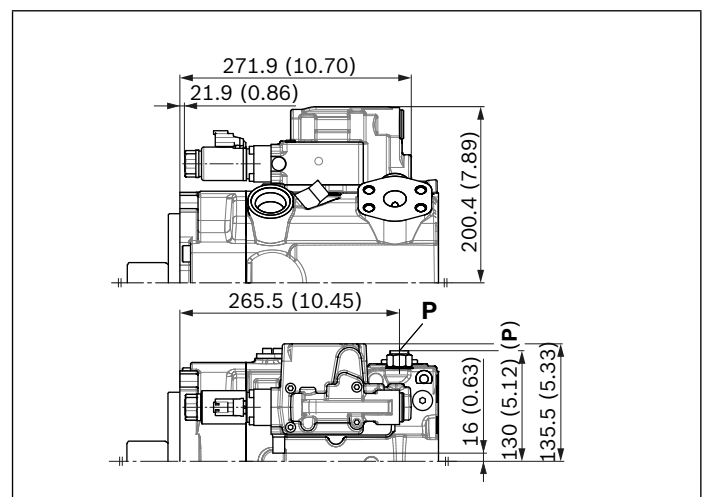

**Notice**

All controllers described with shuttle valve in **P** (some contrary to standard as per ordering code position 08)



▼ **H3/H4** – Stroke control, hydraulic-proportional, pilot pressure

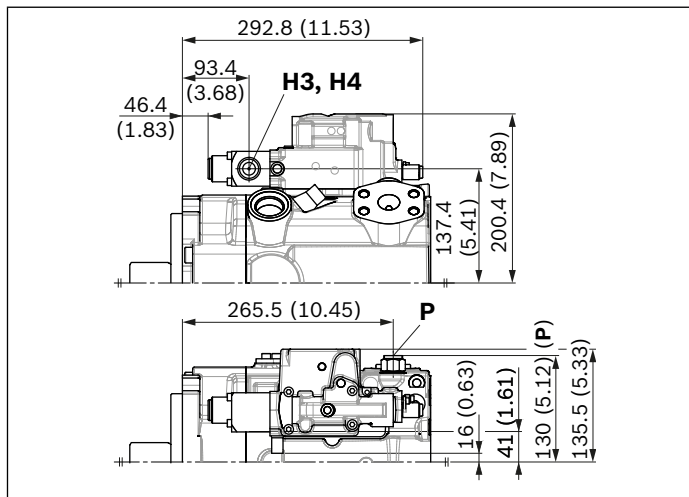

▼ **DR** – Pressure controller, fixed setting

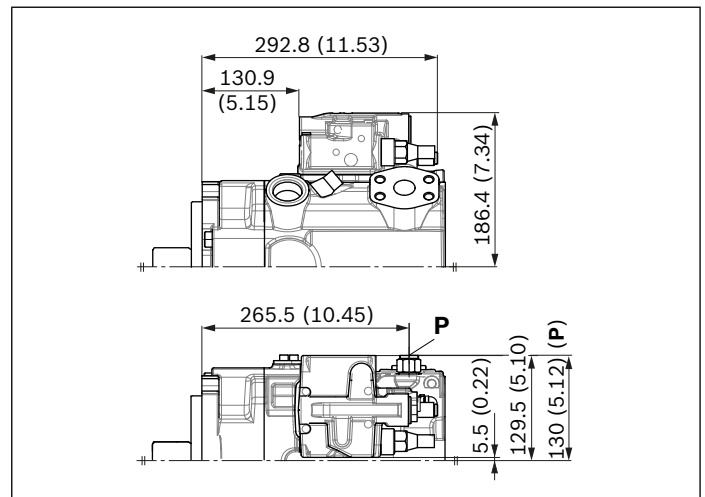

▼ **LRDRSO** – Power controller with pressure controller and load sensing, fixed setting

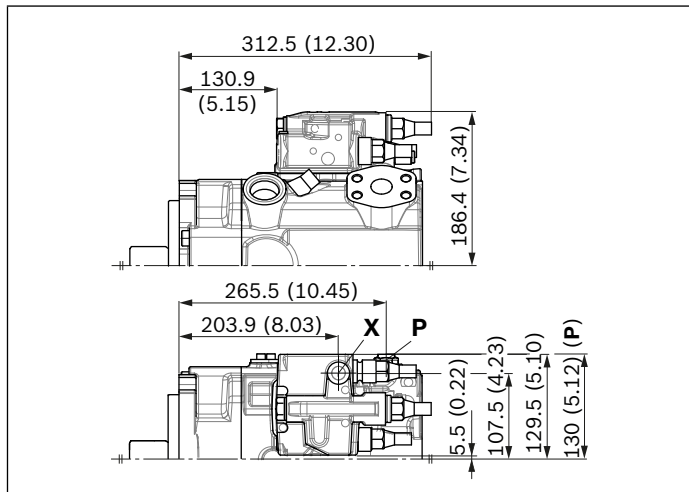

▼ **DG** – Pressure controller, hydraulic, remote controlled

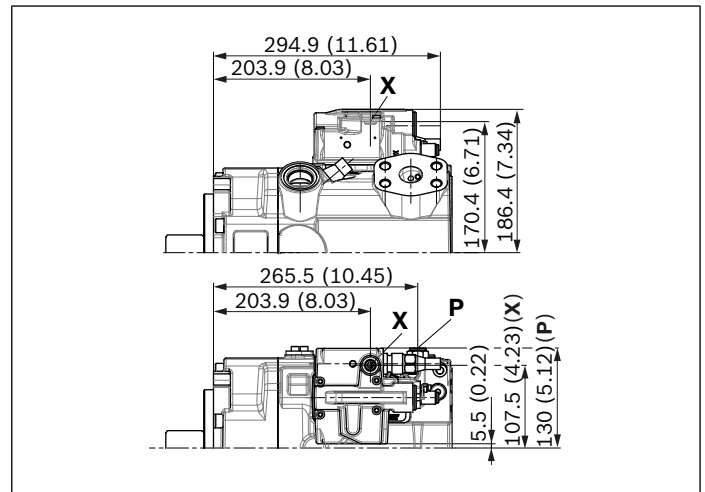

**Notice**

All controllers described with shuttle valve in **P** (some contrary to standard as per ordering code position 08)

**Dimensions size 175**

**LRDRS0 – Power controller with pressure controller, load sensing and with electric swivel angle sensor**

Without charge pump, clockwise rotation

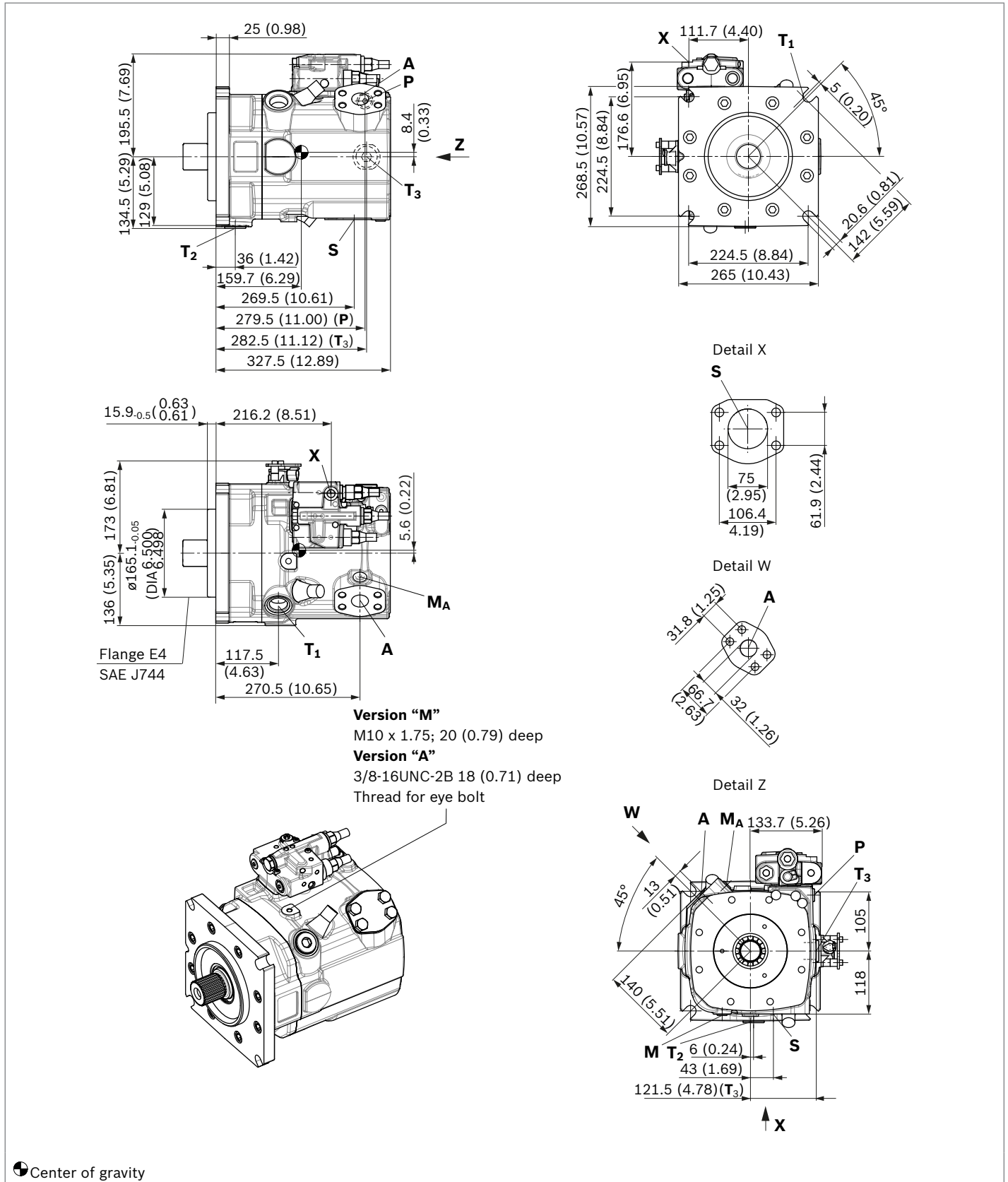

**LRDRS0 – Power controller with pressure controller, load sensing and with electric swivel angle sensor**  
 With charge pump, clockwise rotation

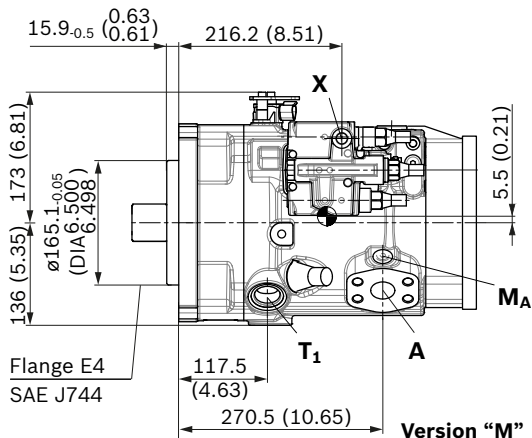
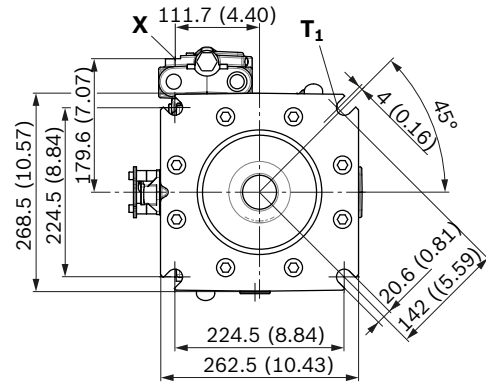
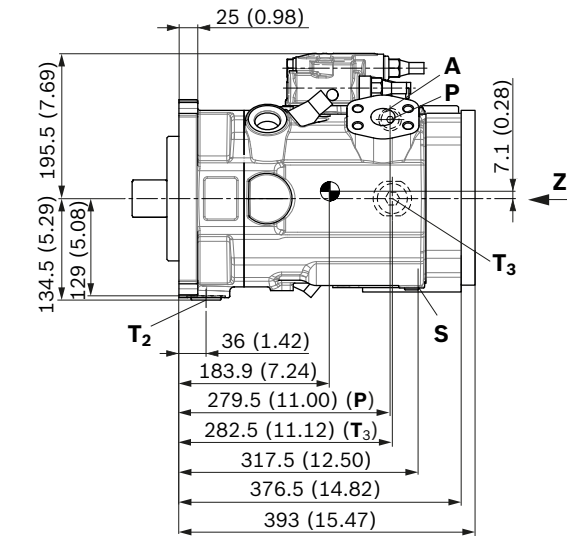

Detail X

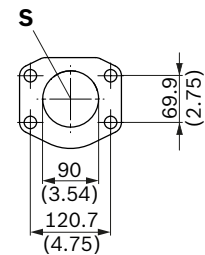

Detail W

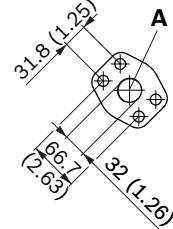

Detail Z

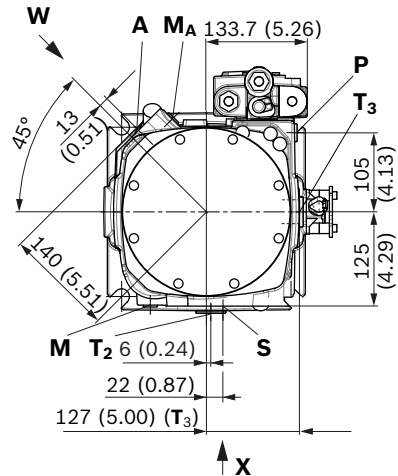

**Version "M"**  
 M10 x 1.75; 20 (0.79) deep  
**Version "A"**  
 3/8-16UNC-2B 18 (0.71) deep  
 Thread for eye bolt

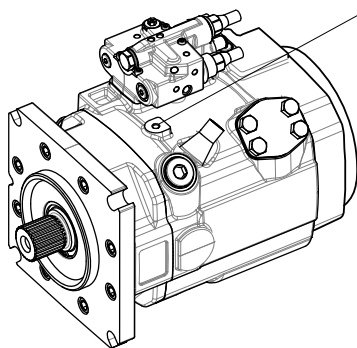

Center of gravity

**LRDRS0 – Power controller with pressure controller, load sensing and without electric swivel angle sensor**

Mounting flange G3 according to SAE J617; 409-12; without charge pump

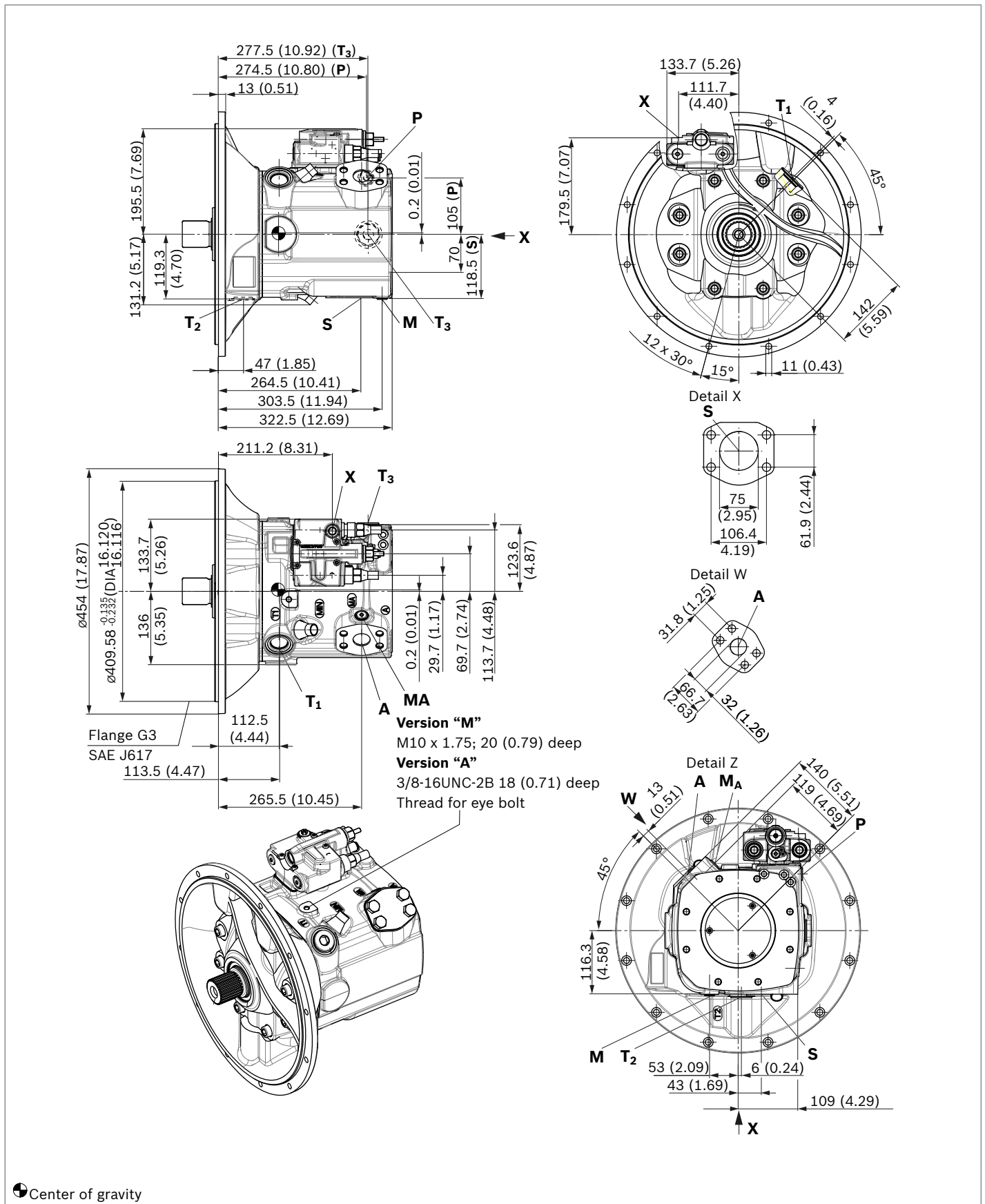

▼ **Splined shaft SAE J744**

**T1** – 1 3/4 in 13T 8/16DP<sup>1)</sup>

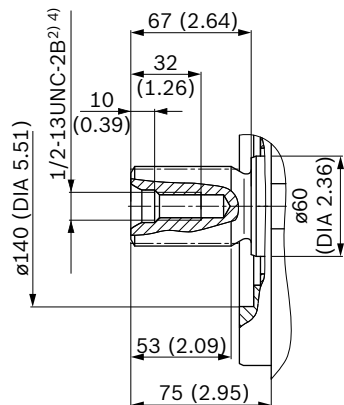

**T2** – 2 in 15T 8/16DP<sup>1)</sup>

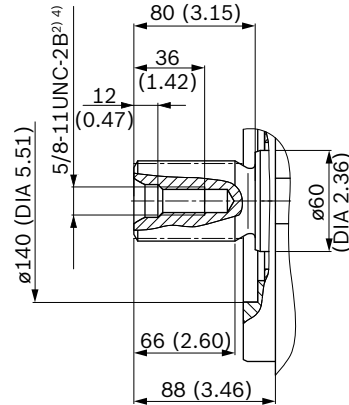

▼ **Splined shaft DIN 5480**

**A2** – W50x2x24x9g

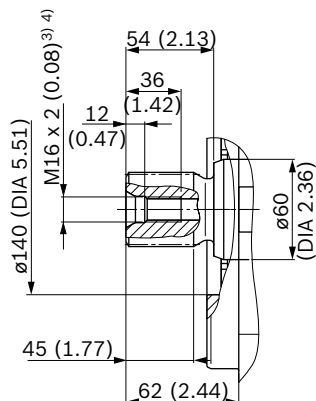

- 1) Involute spline according to ANSI B92.1a, 30° pressure angle, flat root, side fit, tolerance class 5
- 2) Thread according to ASME B1.1
- 3) Center bore according to DIN 332 (thread according to DIN 13)
- 4) Observe the instructions in the operating instructions concerning the maximum tightening torques.

Ports – version “M” metric		Standard	Size <sup>4)</sup>	$p_{\max \text{ abs}}$ [bar (psi)] <sup>5)</sup>	State <sup>9)</sup>
<b>A</b>	Service line	SAE J518 <sup>6)</sup>	1 1/4 in	420 (6100)	O
	Fastening thread	DIN 13	M14 × 2; 22 (0.87) deep		
<b>S</b>	Suction port (without charge pump)	SAE J518 <sup>6)</sup>	3 in	30 (435)	O
	Fastening thread	DIN 13	M16 × 2; 24 (0.94) deep		
<b>S</b>	Suction port (with charge pump)	SAE J518 <sup>6)</sup>	3 1/2 in	2 (30)	O
	Fastening thread	DIN 13	M16 × 2; 24 (0.94) deep		
<b>T<sub>1</sub></b>	Drain port	ISO 6149 <sup>7)</sup>	M33 × 2; 19 (0.75) deep	10 (145)	O <sup>8)</sup>
<b>T<sub>2</sub></b>	Drain port	ISO 6149 <sup>7)</sup>	M33 × 2; 19 (0.75) deep	10 (145)	X <sup>8)</sup>
<b>T<sub>3</sub></b>	Drain port	ISO 6149 <sup>7)</sup>	M33 × 2; 19 (0.75) deep	420 (6100)	X <sup>8)</sup>
<b>CR</b>	Pilot signal (CR only)	ISO 6149	M14 × 1.5; 11.5 (0.45) deep	100 (1450)	O
<b>PR</b>	Pilot signal (PR only)	ISO 6149	M14 × 1.5; 11.5 (0.45) deep	100 (1450)	O
<b>H3, H4</b>	Pilot signal (H3 and H4 only)	ISO 6149	M14 × 1.5; 11.5 (0.45) deep	100 (1450)	O
<b>L5, L6</b>	Override power controller (only with L5 and L6)	ISO 6149	M14 × 1.5; 11.5 (0.45) deep	100 (1450)	O
<b>X</b>	Pilot signal (SO and DG only)	ISO 6149 <sup>7)</sup>	M14 × 1.5; 11.5 (0.45) deep	420 (6100)	O
<b>M</b>	Measuring, control pressure	ISO 6149 <sup>7)</sup>	M14 × 1.5; 12 (0.47) deep	420 (6100)	X
<b>M<sub>A</sub></b>	Measuring, pressure A	ISO 6149 <sup>7)</sup>	M14 × 1.5; 12 (0.47) deep	420 (6100)	X
<b>P</b>	External control pressure (ordering code position 8 version B or C = with external control pressure supply)	ISO 6149 <sup>7)</sup>	M14 × 1.5; 11.5 (0.45) deep	50 (725)	O
	Port <b>P</b> is without function (Ordering code position 8 version A = without external control pressure supply)	ISO 6149 <sup>7)</sup>	M18 × 1.5; 14.5 (0.57) deep	420 (6100)	X

Ports – version “A” SAE		Standard	Size <sup>4)</sup>	$p_{\max \text{ abs}}$ [bar (psi)] <sup>5)</sup>	State <sup>9)</sup>
<b>A</b>	Service line	SAE J518	1 1/4 in	420 (6100)	O
	Fastening thread	ASME B1.1	1/2-13UNC-2B; 19 (0.75) deep		
<b>S</b>	Suction port (without charge pump)	SAE J518	3 in	30 (435)	O
	Fastening thread	ASME B1.1	5/8-11UNC-2B; 24 (0.94) deep		
<b>S</b>	Suction port (with charge pump)	SAE J518	3 1/2 in	2 (30)	O
	Fastening thread	ASME B1.1	5/8-11UNC-2B; 24 (0.94) deep		
<b>T<sub>1</sub></b>	Drain port	ISO 11926 <sup>7)</sup>	1 5/16UNF-2B; 20 (0.79) deep	10 (145)	O <sup>8)</sup>
<b>T<sub>2</sub></b>	Drain port	ISO 11926 <sup>7)</sup>	1 5/16UNF-2B; 20 (0.79) deep	10 (145)	X <sup>8)</sup>
<b>T<sub>3</sub></b>	Drain port	ISO 11926 <sup>7)</sup>	1 5/16UNF-2B; 20 (0.79) deep	420 (6100)	X <sup>8)</sup>
<b>CR</b>	Pilot signal (CR only)	ISO 11926	9/16-18UNF-2B; 13 (0.51) deep	100 (1450)	O
<b>PR</b>	Pilot signal (PR only)	ISO 11926	9/16-18UNF-2B; 13 (0.51) deep	100 (1450)	O
<b>H3, H4</b>	Pilot signal (H3 and H4 only)	ISO 11926	9/16-18UNF-2B; 13 (0.51) deep	100 (1450)	O
<b>L5, L6</b>	Override power controller (only with L5 and L6)	ISO 11926	9/16-18UNF-2B; 13 (0.51) deep	100 (1450)	O
<b>X</b>	Pilot signal (SO and DG only)	ISO 11926 <sup>7)</sup>	9/16-18UNF-2B; 13 (0.51) deep	420 (6100)	O
<b>M</b>	Measuring, control pressure	ISO 11926 <sup>7)</sup>	9/16-18UNF-2B; 13 (0.51) deep	420 (6100)	X
<b>M<sub>A</sub></b>	Measuring, pressure A	ISO 11926 <sup>7)</sup>	9/16-18UNF-2B; 13 (0.51) deep	420 (6100)	X
<b>P</b>	External control pressure (Ordering code position 8 version B or C = with external control pressure supply)	ISO 11926 <sup>7)</sup>	9/16-18UNF-2B; 13 (0.51) deep	50 (725)	O
	Port <b>P</b> is without function (Ordering code position 8 version A = without external control pressure supply)	ISO 11926 <sup>7)</sup>	3/4-16UNF-2B; 12.6 (0.50) deep	420 (6100)	X

5) Depending on the application, momentary pressure peaks can occur.  
Keep this in mind when selecting measuring devices and fittings.

6) Metric fastening thread is a deviation from standard.

7) The countersink can be deeper than as specified in the standard.

8) Depending on installation position, T<sub>1</sub>, T<sub>2</sub> or T<sub>3</sub> must be connected  
(see also Installation instructions on pages 64 and 65).

9) O = Must be connected (plugged when delivered)

X = Plugged (in normal operation)

▼ **LR** – Power controller, fixed setting

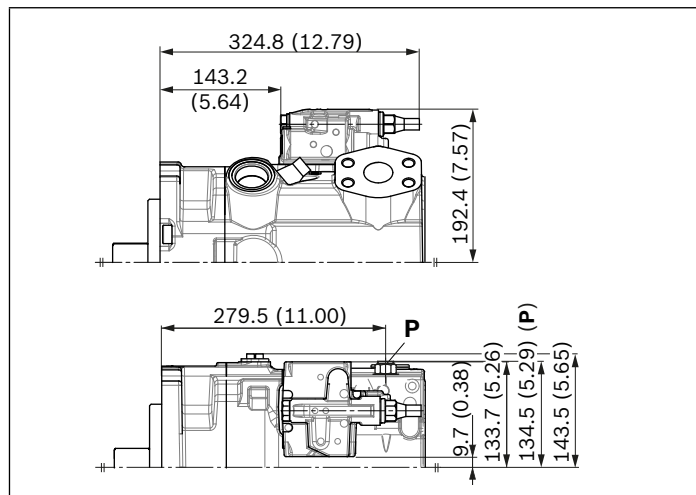

▼ **L3/L4** – Power controller, electric-proportional override

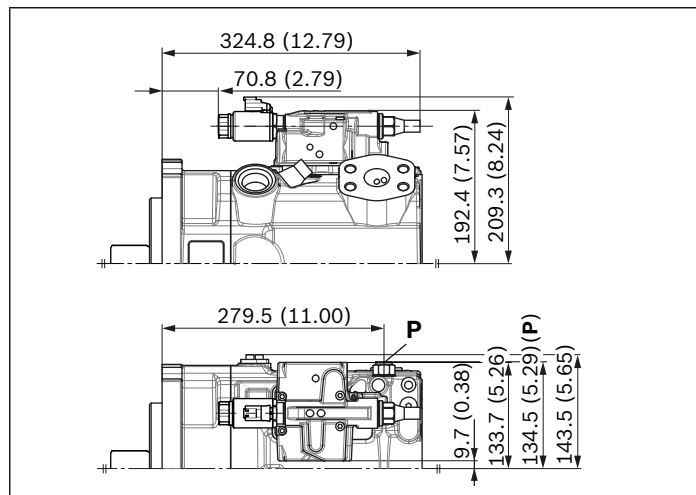

▼ **L5/L6** – Power controller, hydraulic override

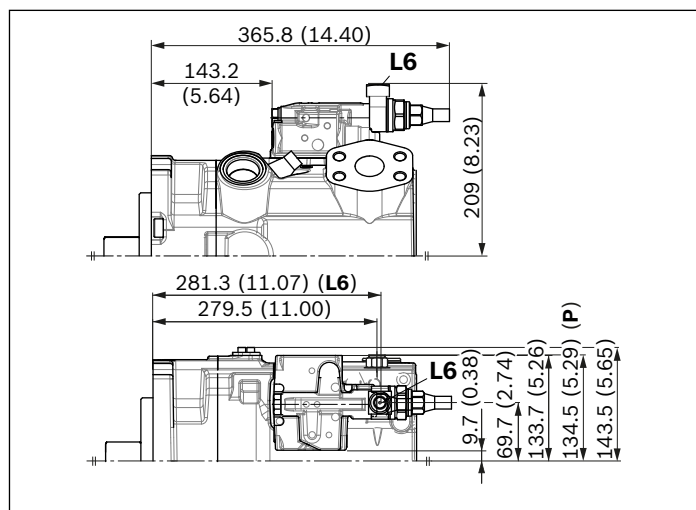

▼ **CR** – Power controller, hydraulic-proportional override, high pressure, with stop

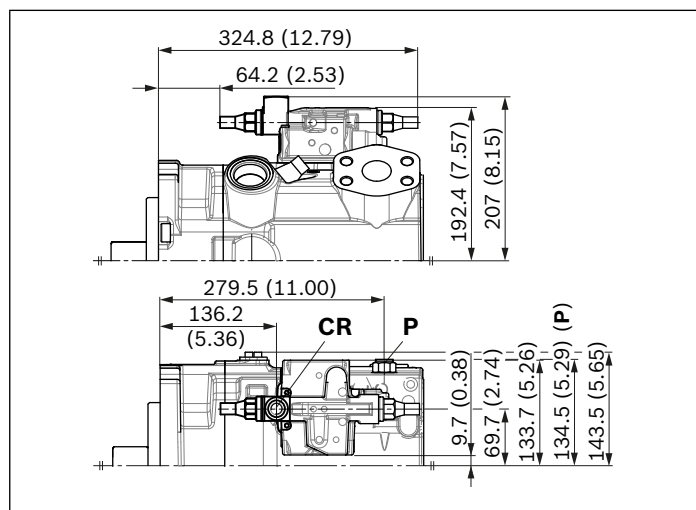

▼ **PR** – Power controller, hydraulic-proportional override, high pressure, without stop

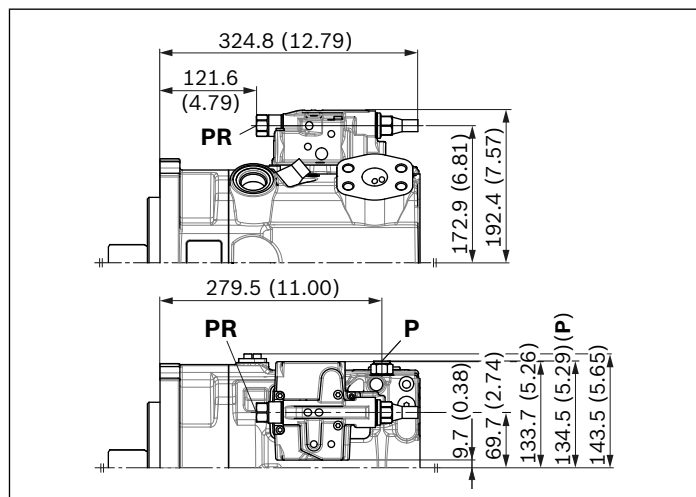

▼ **E1/E2** – Stroke control electric-proportional

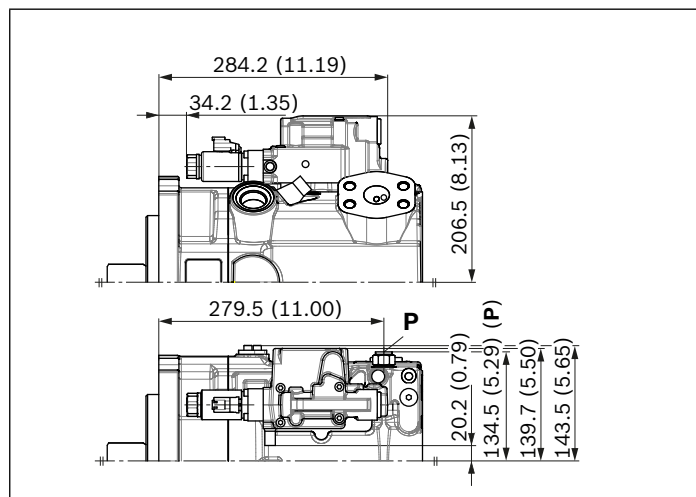

**Notice**

All controllers described with shuttle valve in **P** (some contrary to standard as per ordering code position 08)

▼ **H3/H4** – Stroke control, hydraulic-proportional, pilot pressure

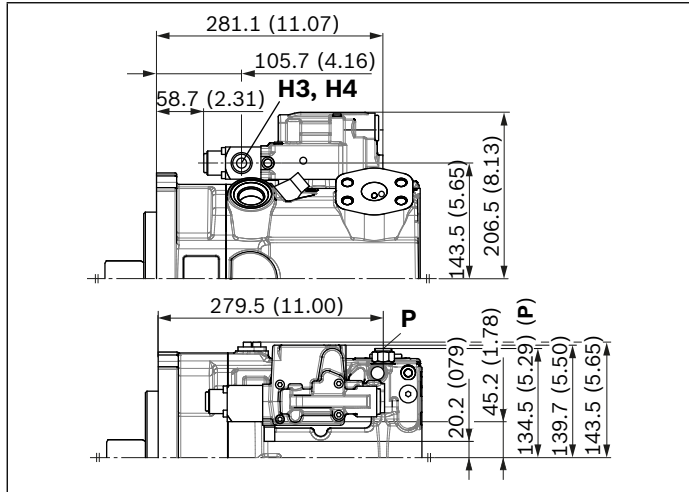

▼ **DR** – Pressure controller, fixed setting

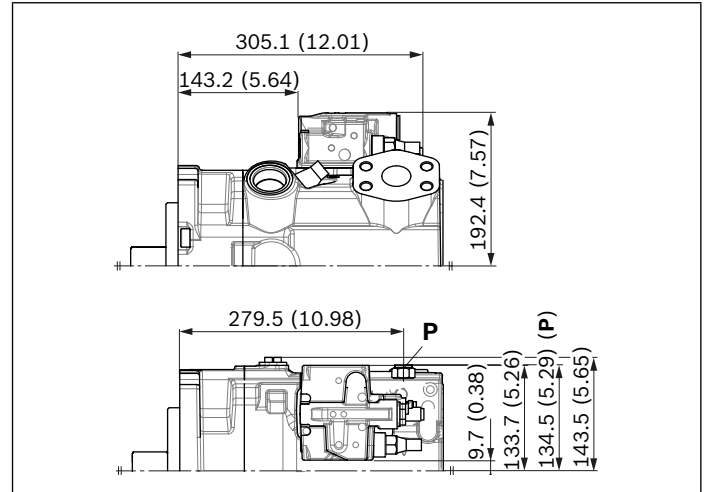

▼ **LRDRS0** – Power controller with pressure controller and load sensing, fixed setting

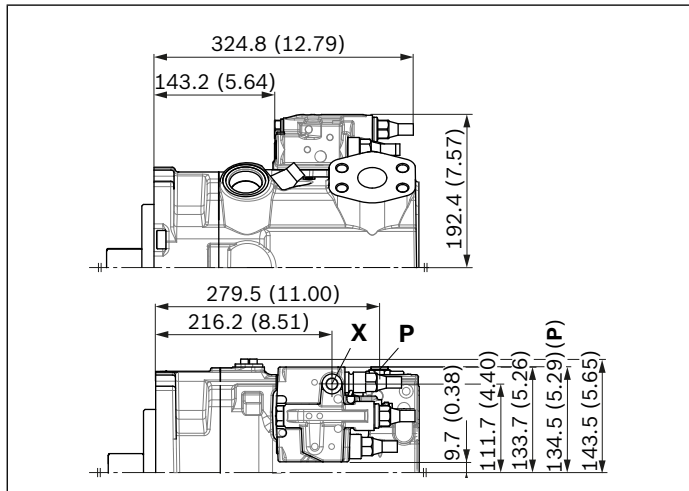

▼ **DG** – Pressure controller, hydraulic, remote controlled

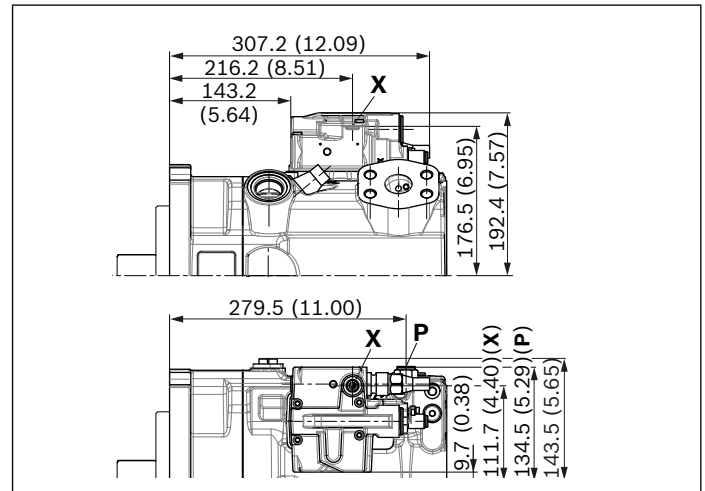

**Notice**

All controllers described with shuttle valve in **P** (some contrary to standard as per ordering code position 08)



**Dimensions size 210**

**LRDRS0 – Power controller with pressure controller, load sensing and with electric swivel angle sensor**

Without charge pump, clockwise rotation

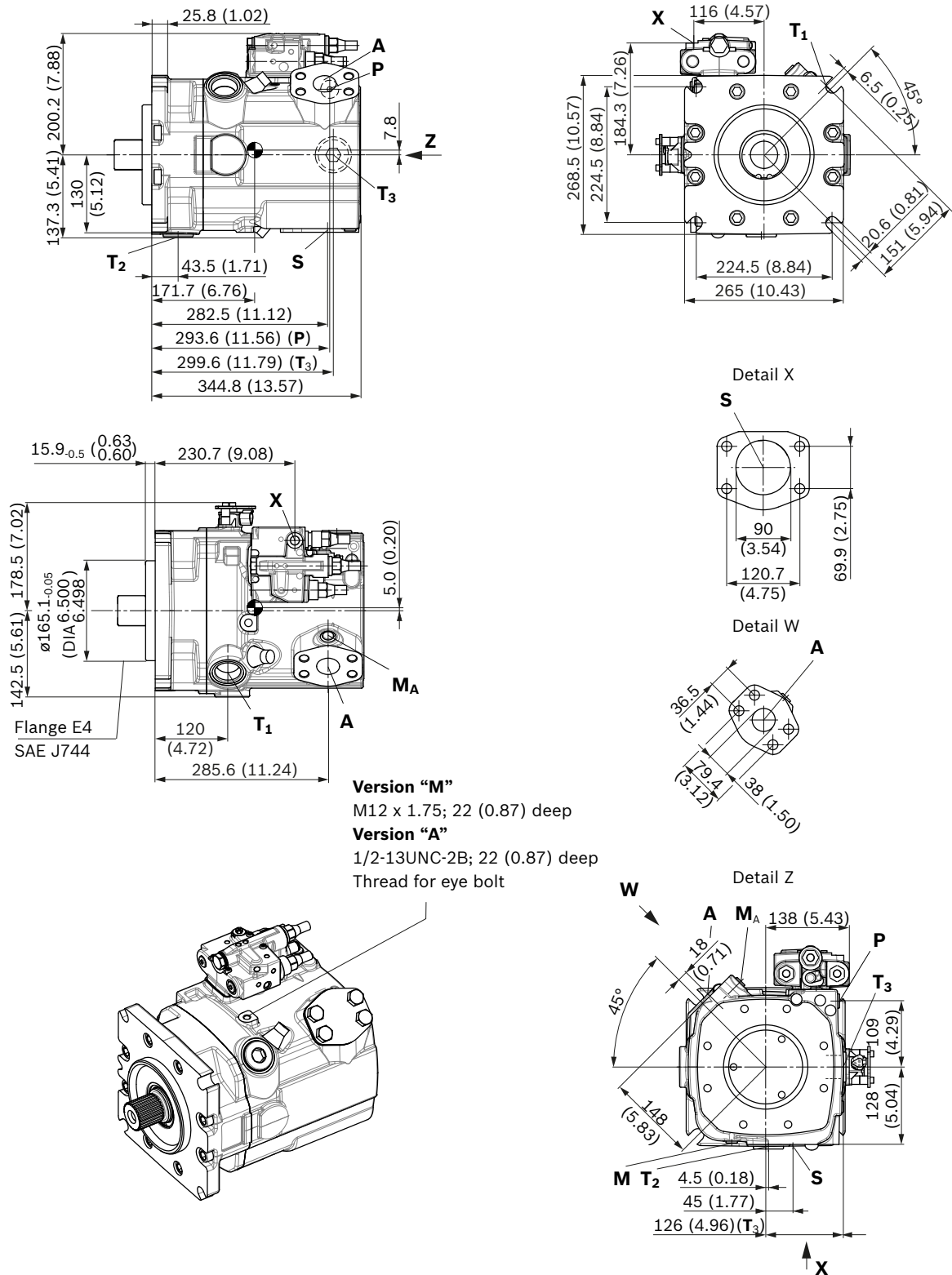

**LRDRS0 – Power controller with pressure controller, load sensing and with electric swivel angle sensor**

With charge pump, clockwise rotation

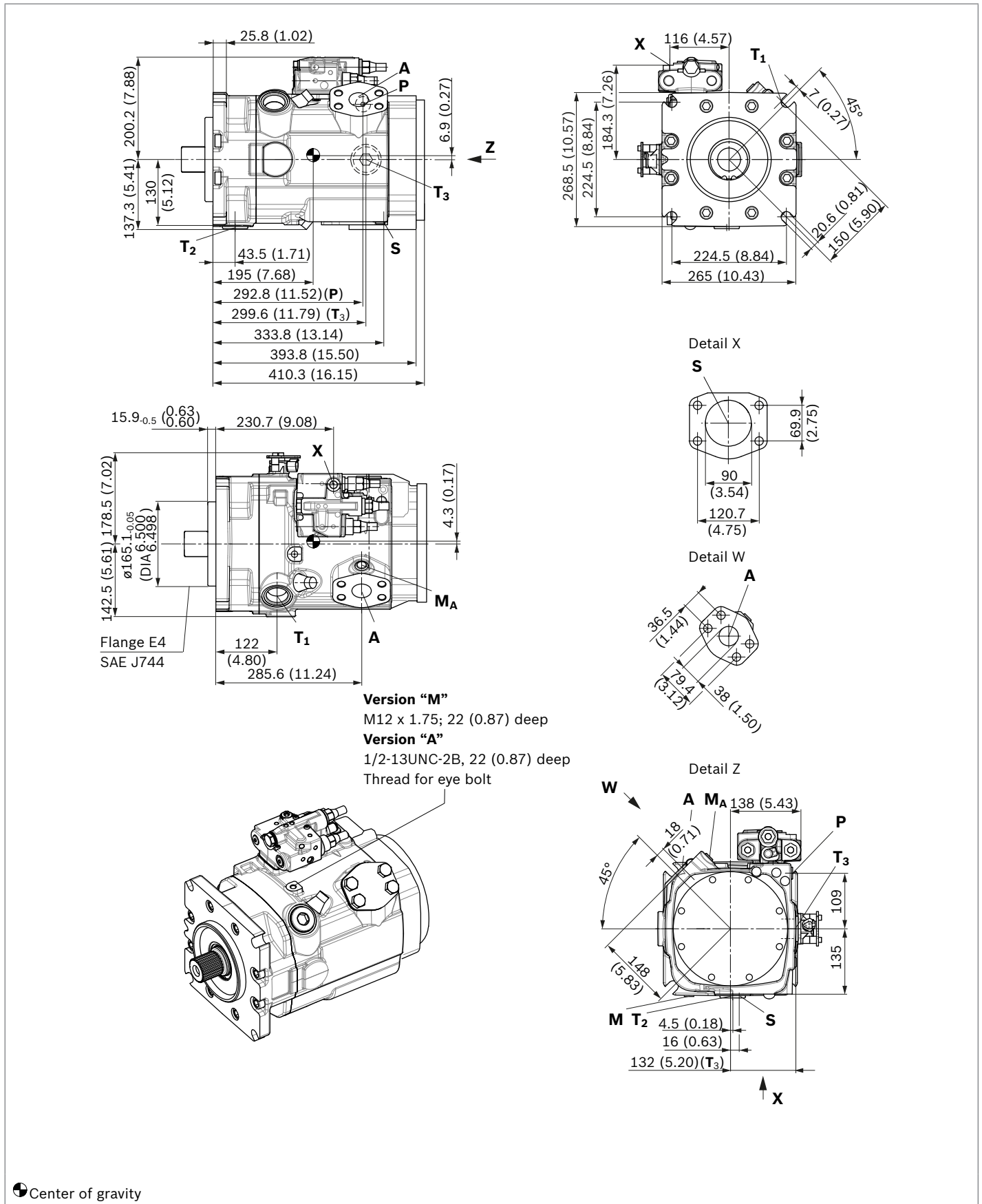

**L5E2 – Power controller with pressure controller, load sensing and with electric swivel angle sensor**

Mounting flange G3 according to SAE J617; 409-12; without charge pump

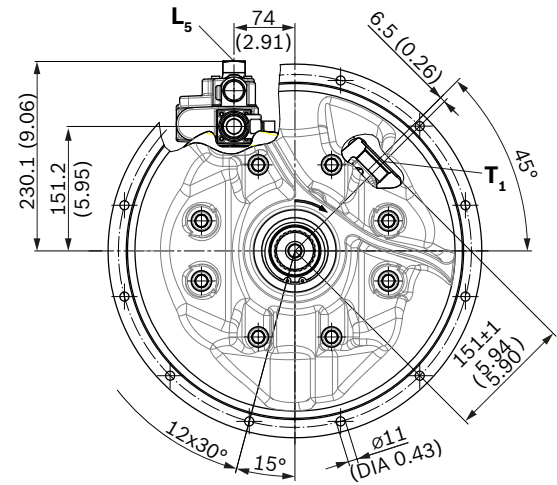
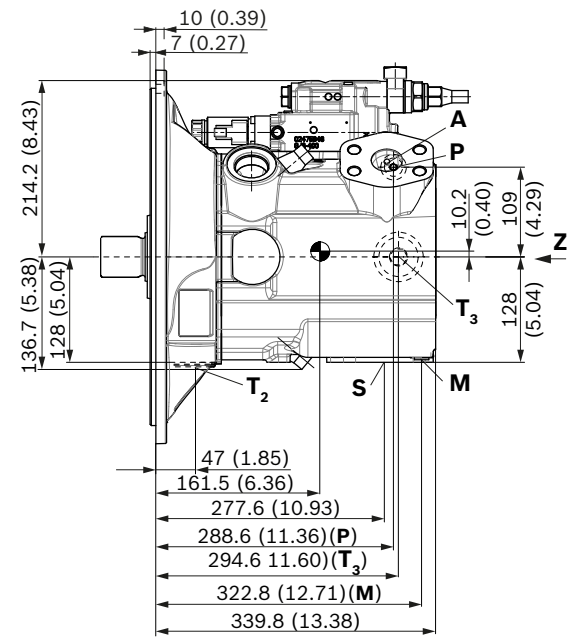

Detail X

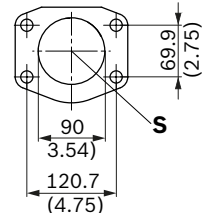

Detail W

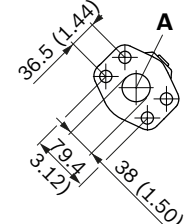

Detail Z

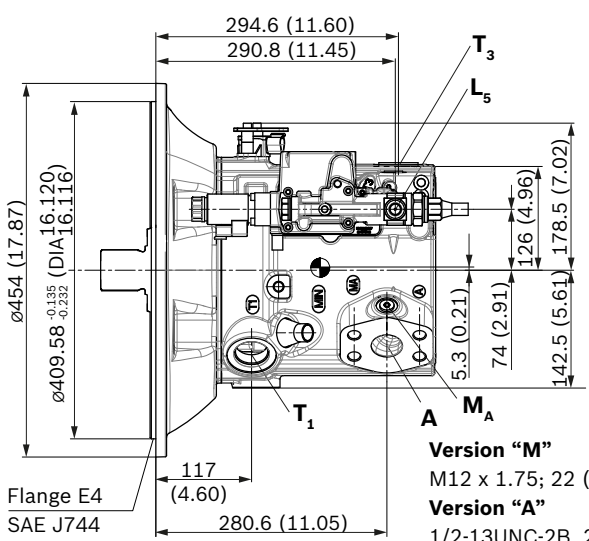
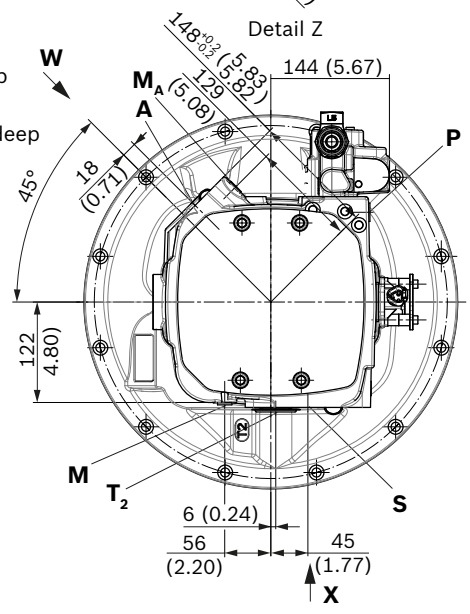

Version "M"  
 M12 x 1.75; 22 (0.87) deep  
 Version "A"  
 1/2-13UNC-2B, 22 (0.87) deep  
 Thread for eye bolt

Flange E4  
 SAE J744

Ø454 (17.87)  
 Ø409.58<sup>+0.135</sup><sub>-0.232</sub> (DIA 16.120)  
 16.116

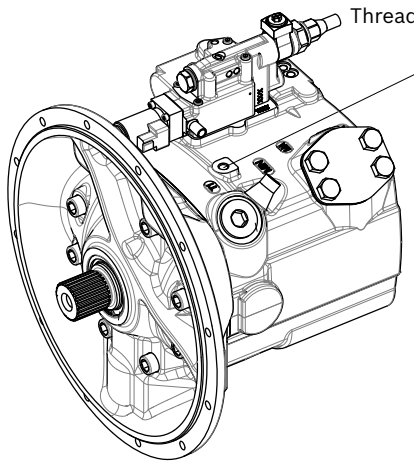

Center of gravity

▼ **Splined shaft SAE J744**

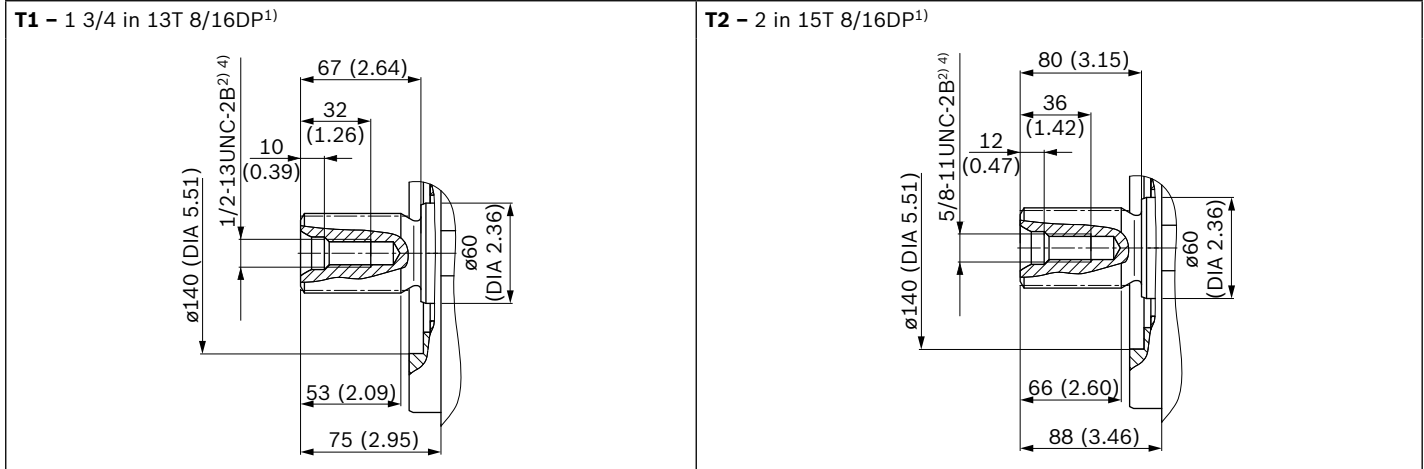

▼ **Splined shaft DIN 5480**

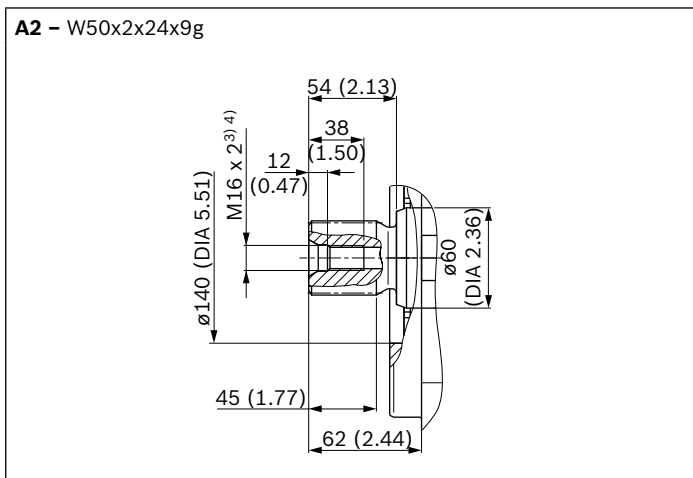

- 1) Involute spline according to ANSI B92.1a, 30° pressure angle, flat root, side fit, tolerance class 5
- 2) Thread according to ASME B1.1
- 3) Center bore according to DIN 332 (thread according to DIN 13)
- 4) Observe the instructions in the operating instructions concerning the maximum tightening torques.

Ports – version “M” metric		Standard	Size <sup>4)</sup>	$p_{\max \text{ abs}}$ [bar (psi)] <sup>5)</sup>	State <sup>9)</sup>
<b>A</b>	Service line	SAE J518 <sup>6)</sup>	1 1/2 in	420 (6100)	O
	Fastening thread	DIN 13	M16 x 2; 24 (0.94) deep		
<b>S</b>	Suction port (without charge pump)	SAE J518 <sup>6)</sup>	3 1/2 in	30 (435)	O
	Fastening thread	DIN 13	M16 x 2; 24 (0.94) deep		
<b>S</b>	Suction port (with charge pump)	SAE J518 <sup>6)</sup>	3 1/2 in	2 (30)	O
	Fastening thread	DIN 13	M16 x 2; 24 (0.94) deep		
<b>T<sub>1</sub></b>	Drain port	ISO 6149 <sup>7)</sup>	M42 x 2; 19.5 (0.77) deep	10 (145)	O <sup>8)</sup>
<b>T<sub>2</sub></b>	Drain port	ISO 6149 <sup>7)</sup>	M42 x 2; 19.5 (0.77) deep	10 (145)	X <sup>8)</sup>
<b>T<sub>3</sub></b>	Drain port	ISO 6149 <sup>7)</sup>	M42 x 2; 19.5 (0.77) deep	10 (145)	X <sup>8)</sup>
<b>CR</b>	Pilot signal (CR only)	ISO 6149	M14 x 1.5; 11.5 (0.45) deep	420 (6100)	O
<b>PR</b>	Pilot signal (PR only)	ISO 6149	M14 x 1.5; 11.5 (0.45) deep	420 (6100)	O
<b>H3, H4</b>	Pilot signal (H3 and H4 only)	ISO 6149	M14 x 1.5; 11.5 (0.45) deep	100 (1450)	O
<b>L5, L6</b>	Override power controller (only with L5 and L6)	ISO 6149	M14 x 1.5; 11.5 (0.45) deep	100 (1450)	O
<b>X</b>	Pilot signal (S0 and DG only)	ISO 6149 <sup>7)</sup>	M14 x 1.5; 11.5 (0.45) deep	420 (6100)	O
<b>M</b>	Measuring, control pressure	ISO 6149 <sup>7)</sup>	M14 x 1.5; 12 (0.47) deep	420 (6100)	X
<b>M<sub>A</sub></b>	Measuring, pressure A	ISO 6149 <sup>7)</sup>	M14 x 1.5; 12 (0.47) deep	420 (6100)	X
<b>P</b>	External control pressure (Ordering code position 8 version B or C = with external control pressure supply)	ISO 6149 <sup>7)</sup>	M14 x 1.5; 11.5 (0.45) deep	50 (725)	O
	Port <b>P</b> is without function (Ordering code position 8 version A = without external control pressure supply)	ISO 6149 <sup>7)</sup>	M18 x 1.5; 14.5 deep	420 (6100)	X

Ports – version “A” SAE		Standard	Size <sup>4)</sup>	$p_{\max \text{ abs}}$ [bar (psi)] <sup>5)</sup>	State <sup>9)</sup>
<b>A</b>	Service line	SAE J518	1 1/2 in	420 (6100)	O
	Fastening thread	ASME B1.1	5/8-11UNC-2B; 30 (1.18) deep		
<b>S</b>	Suction port (without charge pump)	SAE J518	3 1/2 in	30 (435)	O
	Fastening thread	ASME B1.1	5/8-11UNC-2B; 30 (1.18) deep		
<b>S</b>	Suction port (with charge pump)	SAE J518 <sup>4)</sup>	3 1/2 in	2 (30)	O
	Fastening thread	ASME B1.1	5/8-11UNC-2B; 30 (1.18) deep		
<b>T<sub>1</sub></b>	Drain port	ISO 11926 <sup>7)</sup>	1 5/8-12UNF-2B; 20 (0.79) deep	10 (145)	O <sup>8)</sup>
<b>T<sub>2</sub></b>	Drain port	ISO 11926 <sup>7)</sup>	1 5/8-12UNF-2B; 20 (0.79) deep	10 (145)	X <sup>8)</sup>
<b>T<sub>3</sub></b>	Drain port	ISO 11926 <sup>7)</sup>	1 5/8-12UNF-2B; 20 (0.79) deep	10 (145)	X <sup>8)</sup>
<b>CR</b>	Pilot signal (CR only)	ISO 11926	9/16-18UNF-2B; 13 (0.51) deep	420 (6100)	O
<b>PR</b>	Pilot signal (PR only)	ISO 11926	9/16-18UNF-2B; 13 (0.51) deep	420 (6100)	O
<b>H3, H4</b>	Pilot signal (H3 and H4 only)	ISO 11926	9/16-18UNF-2B; 13 (0.51) deep	100 (1450)	O
<b>L5, L6</b>	Override power controller (only with L5 and L6)	ISO 11926	9/16-18UNF-2B; 13 (0.51) deep	100 (1450)	O
<b>X</b>	Pilot signal (S0 and DG only)	ISO 11926 <sup>7)</sup>	9/16-18UNF-2B; 13 (0.51) deep	420 (6100)	O
<b>M</b>	Measuring, control pressure	ISO 11926 <sup>7)</sup>	9/16-18UNF-2B; 13 (0.51) deep	420 (6100)	X
<b>M<sub>A</sub></b>	Measuring, pressure A	ISO 11926 <sup>7)</sup>	9/16-18UNF-2B; 13 (0.51) deep	420 (6100)	X
<b>P</b>	External control pressure (Ordering code position 8 version B or C = with external control pressure supply)	ISO 11926 <sup>7)</sup>	9/16-18UNF-2B; 13 (0.51) deep	50 (725)	O
	Port <b>P</b> is without function (Ordering code position 8 version A = without external control pressure supply)	ISO 11926 <sup>7)</sup>	3/4-16UNF-2B; 12.6 (0.50) deep	420 (6100)	X

5) Depending on the application, momentary pressure peaks can occur.  
Keep this in mind when selecting measuring devices and fittings.

6) Metric fastening thread is a deviation from standard.

7) The countersink can be deeper than as specified in the standard.

8) Depending on installation position, T<sub>1</sub>, T<sub>2</sub> or T<sub>3</sub> must be connected  
(see also Installation instructions on pages 64 and 65).

9) O = Must be connected (plugged when delivered)

X = Plugged (in normal operation)

▼ **LR** – Power controller, fixed setting

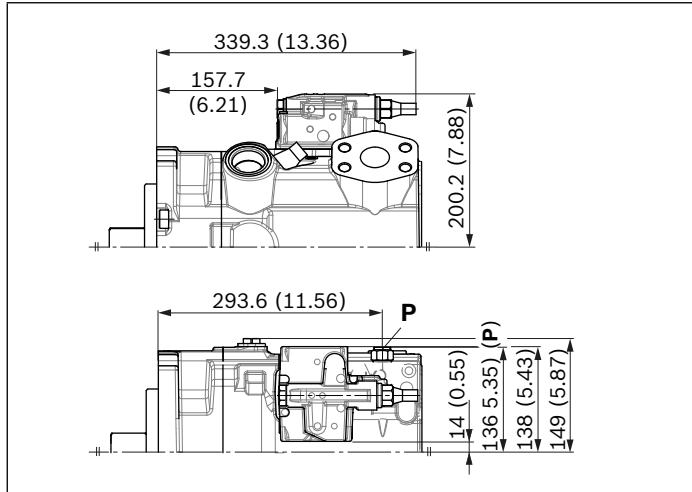

▼ **L3/L4** – Power controller, electric-proportional override

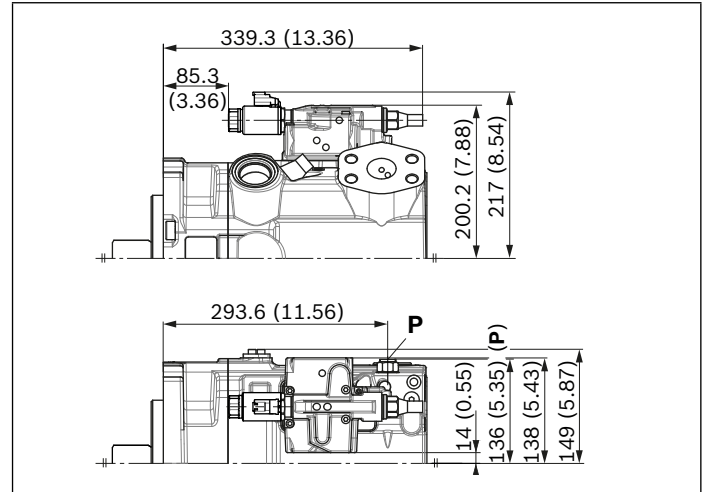

▼ **L5/L6** – Power controller, hydraulic override

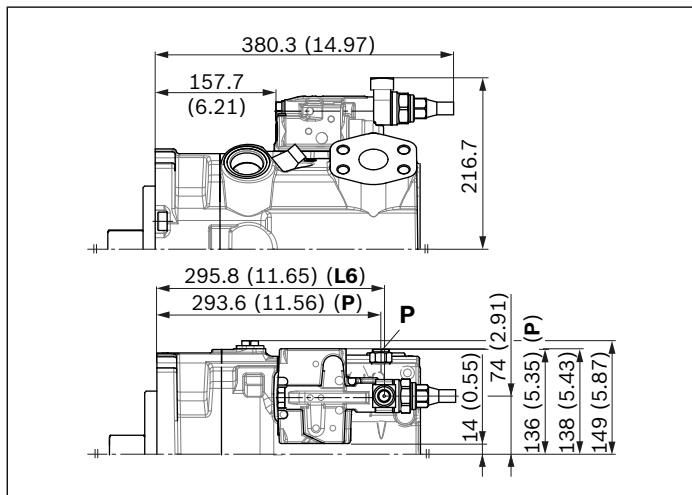

▼ **CR** – Power controller, hydraulic-proportional override, high pressure, with stop

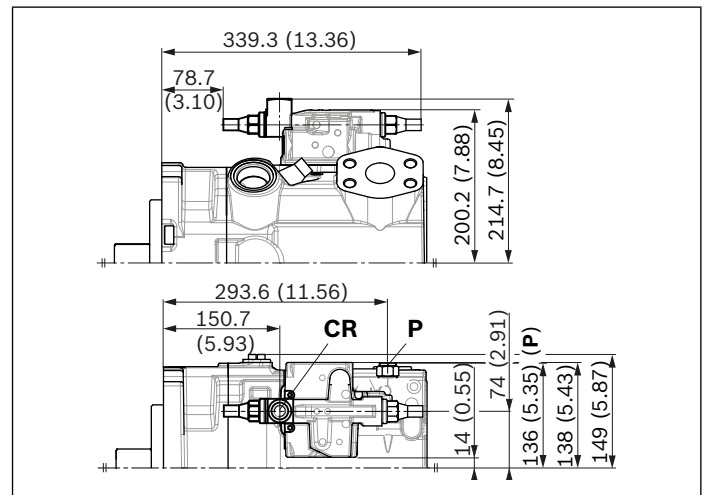

▼ **PR** – Power controller, hydraulic-proportional override, high pressure, without stop

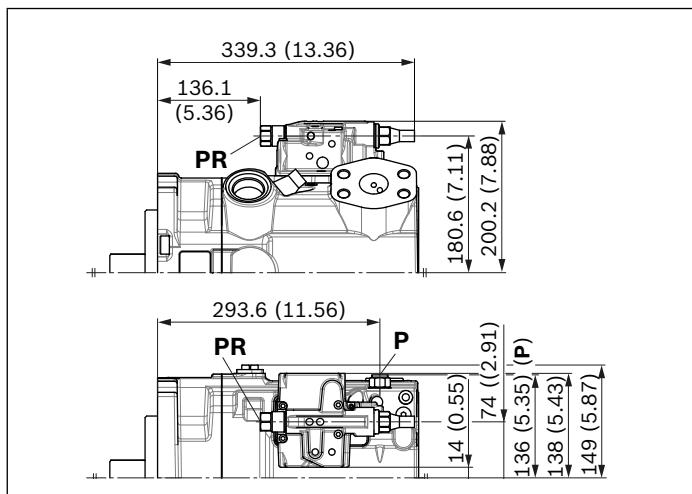

▼ **E1/E2** – Stroke control electric-proportional

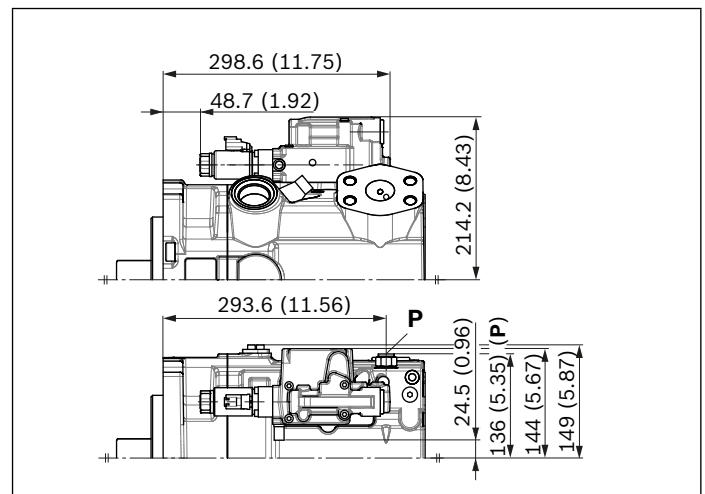

**Notice**

All controllers described with shuttle valve in **P** (some contrary to standard as per ordering code position 08)

▼ **H3/H4** – Stroke control, hydraulic-proportional, pilot pressure

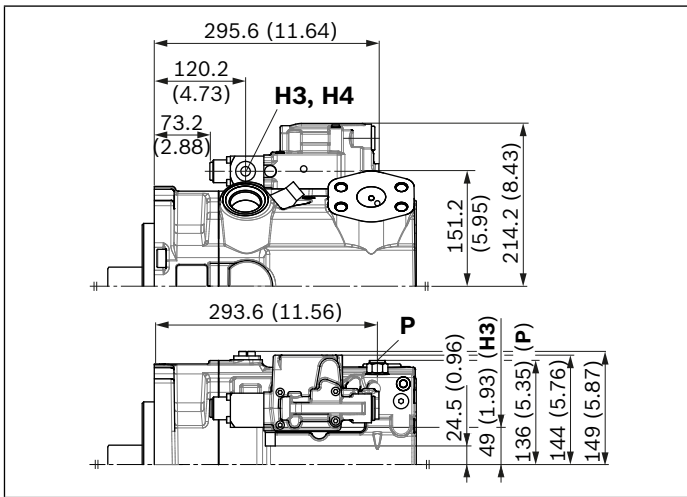

▼ **DR** – Pressure controller, fixed setting

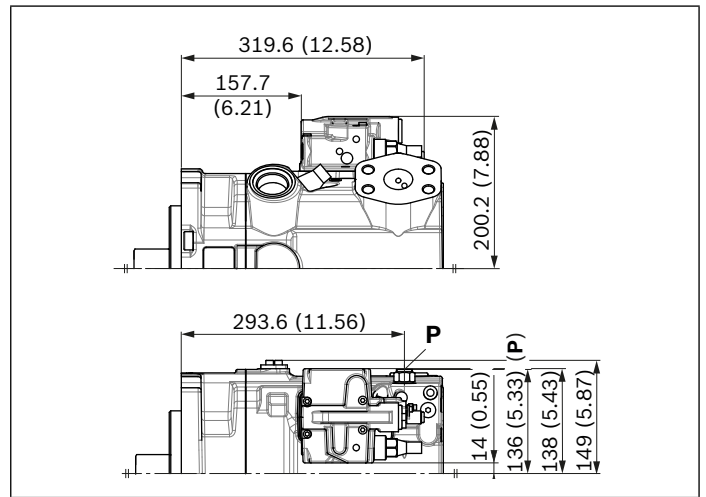

▼ **LRDRSO** – Power controller with pressure controller and load sensing, fixed setting

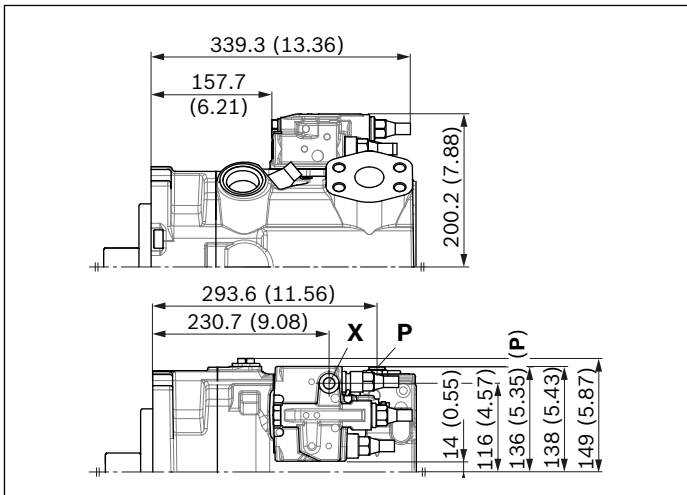

▼ **DG** – Pressure controller, hydraulic, remote controlled

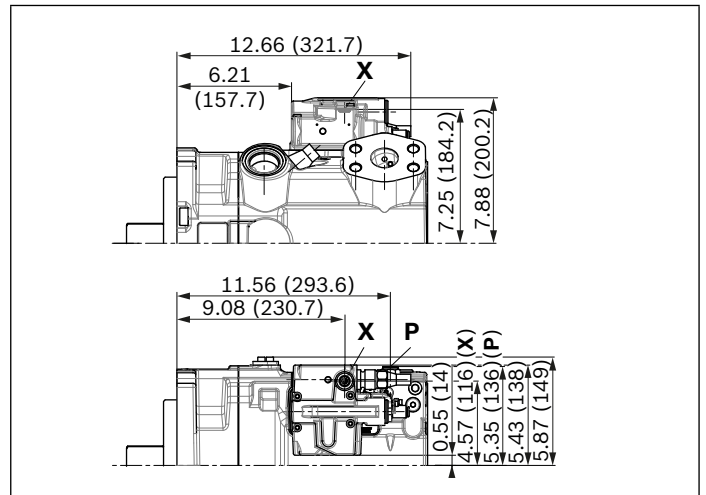

**Notice**

All controllers described with shuttle valve in **P** (some contrary to standard as per ordering code position 08)



**Dimensions size 280**

**LRDRS0 – Power controller with pressure controller, load sensing and with electric swivel angle sensor**

Without charge pump, clockwise rotation

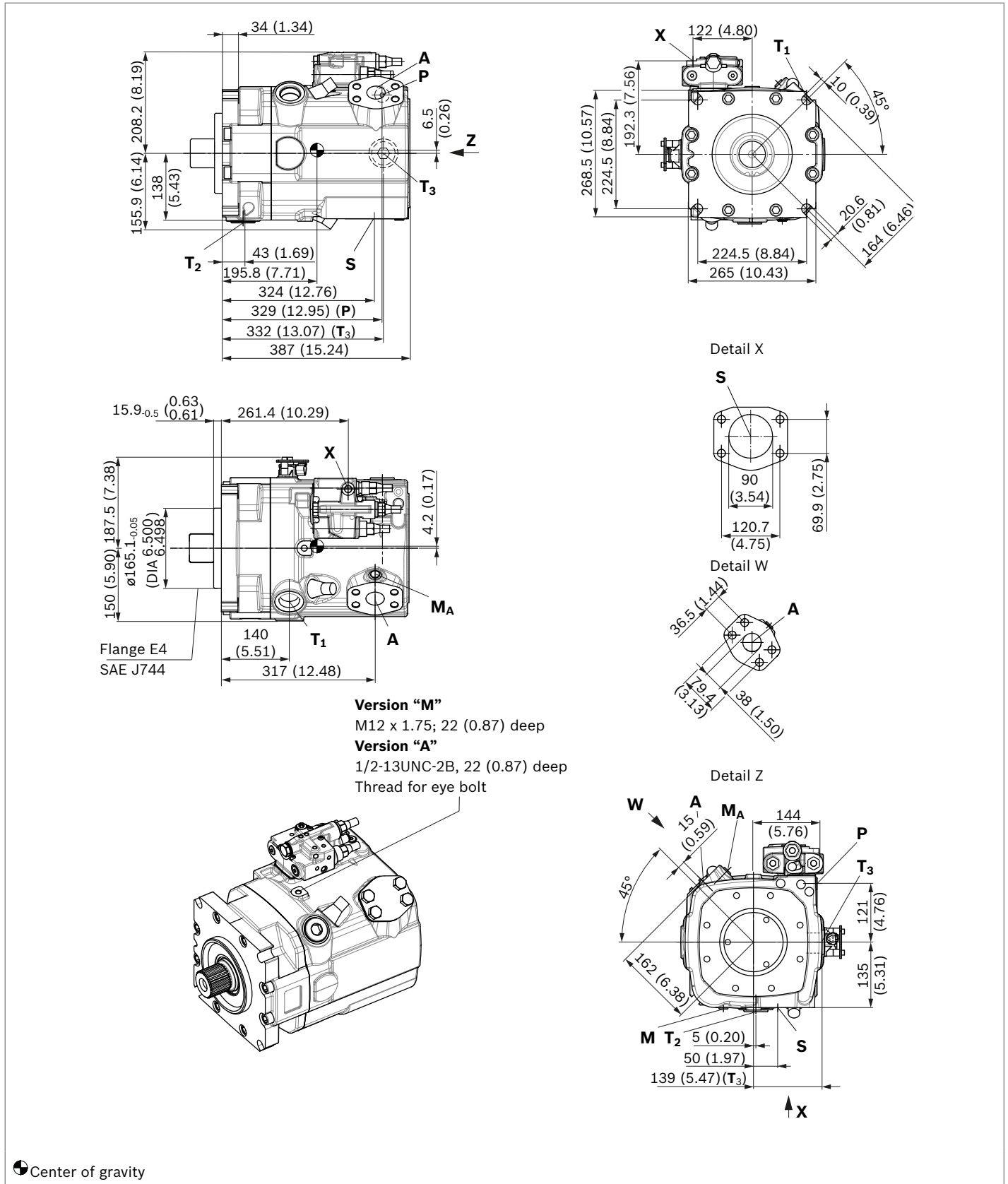



**LRDRS0 – Power controller with pressure controller, load sensing and with electric swivel angle sensor**

With charge pump, clockwise rotation

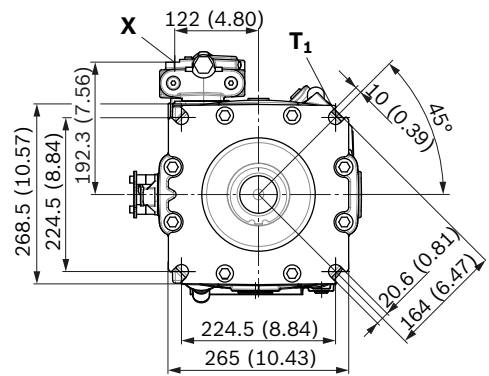
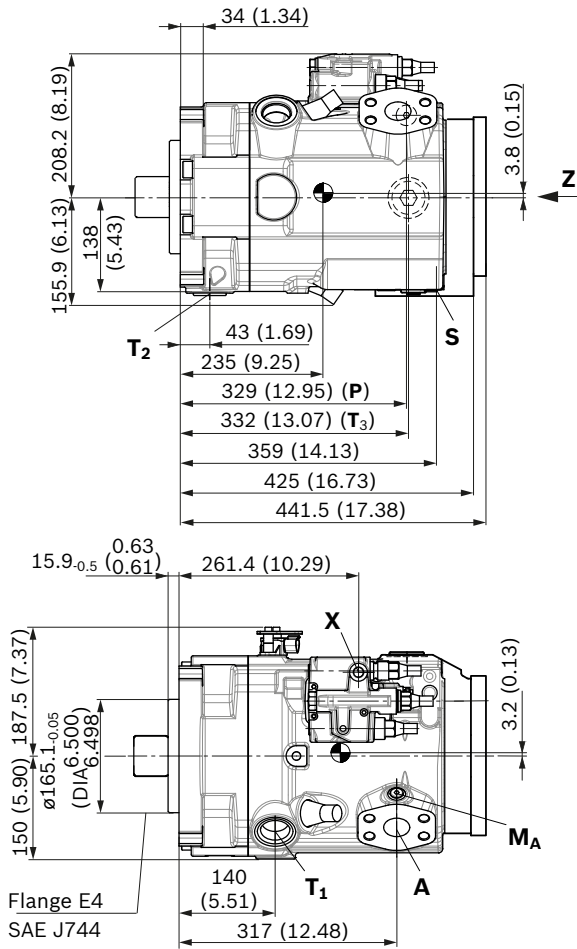

Detail X

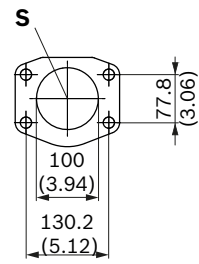

Detail W

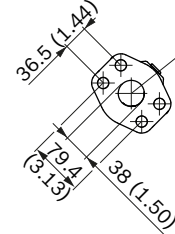

Detail Z

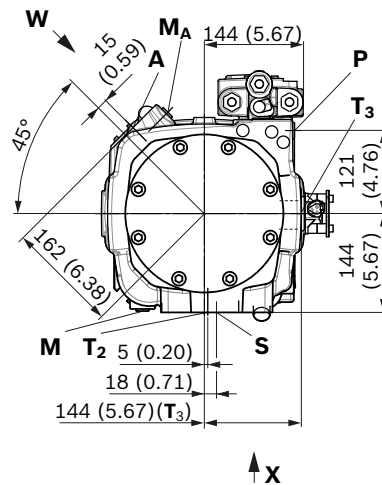

**Version "M"**  
 M12 x 1.75; 22 (0.87) deep  
**Version "A"**  
 1/2-13UNC-2B, 22 (0.87) deep  
 Thread for eye bolt

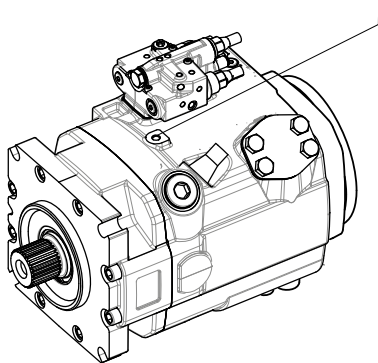

▼ **Splined shaft SAE J744**

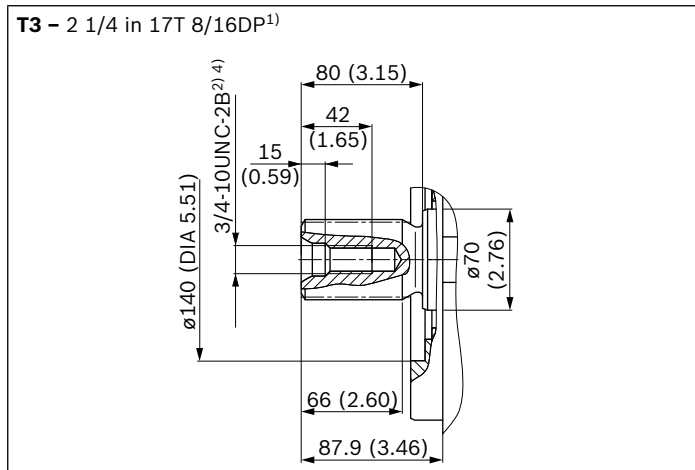

▼ **Splined shaft DIN 5480**

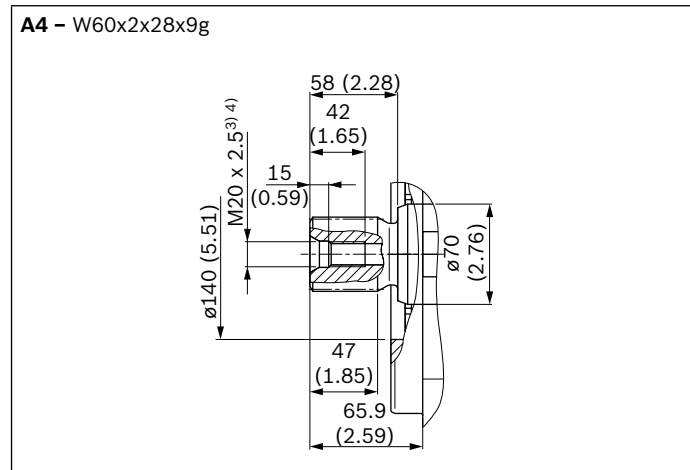

- 1) Involute spline according to ANSI B92.1a, 30° pressure angle, flat root, side fit, tolerance class 5
- 2) Thread according to ASME B1.1
- 3) Center bore according to DIN 332 (thread according to DIN 13)
- 4) Observe the instructions in the operating instructions concerning the maximum tightening torques.

Ports – version “M” metric		Standard	Size <sup>1)</sup>	$p_{\max \text{ abs}}$ [bar (psi)] <sup>2)</sup>	State <sup>6)</sup>
<b>A</b>	Service line	SAE J518 <sup>3)</sup>	1 1/2 in	420 (6100)	O
	Fastening thread	DIN 13	M16 x 2; 24 (0.94) deep		
<b>S</b>	Suction port (without charge pump)	SAE J518 <sup>3)</sup>	3 1/2 in	30 (435)	O
	Fastening thread	DIN 13	M16 x 2; 24 (0.94) deep		
<b>S</b>	Suction port (with charge pump)	SAE J518 <sup>3)</sup>	4 in	2 (30)	O
	Fastening thread	DIN 13	M16 x 2; 24 (0.94) deep		
<b>T<sub>1</sub></b>	Drain port	ISO 6149 <sup>4)</sup>	M42 x 2; 19.5 (0.77) deep	10 (145)	O <sup>5)</sup>
<b>T<sub>2</sub></b>	Drain port	ISO 6149 <sup>4)</sup>	M42 x 2; 19.5 (0.77) deep	10 (145)	X <sup>5)</sup>
<b>T<sub>3</sub></b>	Drain port	ISO 6149 <sup>4)</sup>	M42 x 2; 19.5 (0.77) deep	10 (145)	X <sup>5)</sup>
<b>CR</b>	Pilot signal (CR only)	ISO 6149	M14 x 1.5; 11.5 (0.45) deep	420 (6100)	O
<b>PR</b>	Pilot signal (PR only)	ISO 6149	M14 x 1.5; 11.5 (0.45) deep	420 (6100)	O
<b>H3, H4</b>	Pilot signal (H3 and H4 only)	ISO 6149	M14 x 1.5; 11.5 (0.45) deep	100 (1450)	O
<b>L5, L6</b>	Override power controller (only with L5 and L6)	ISO 6149	M14 x 1.5; 11.5 (0.45) deep	100 (1450)	O
<b>X</b>	Pilot signal (S0 and DG only)	ISO 6149 <sup>4)</sup>	M14 x 1.5; 11.5 (0.45) deep	420 (6100)	O
<b>M</b>	Measuring, control pressure	ISO 6149 <sup>4)</sup>	M14 x 1.5; 12 (0.47) deep	420 (6100)	X
<b>M<sub>A</sub></b>	Measuring, pressure A	ISO 6149 <sup>4)</sup>	M14 x 1.5; 12 (0.47) deep	420 (6100)	X
<b>P</b>	External control pressure (ordering code position 8 version B or C = with external control pressure supply)	ISO 6149 <sup>4)</sup>	M14 x 1.5; 11.5 (0.45) deep	50 (725)	O
	Port <b>P</b> is without function (Ordering code position 8 version A = without external control pressure supply)	ISO 6149 <sup>4)</sup>	M18 x 1.5; 14.5 (0.57) deep	420 (6100)	X

Ports – version “A” SAE		Standard	Size <sup>1)</sup>	$p_{\max \text{ abs}}$ [bar (psi)] <sup>2)</sup>	State <sup>6)</sup>
<b>A</b>	Service line	SAE J518	1 1/2 in	420 (6100)	O
	Fastening thread	ASME B1.1	5/8-11UNC-2B; 35 <sup>7)</sup> (1.38) deep		
<b>S</b>	Suction port (without charge pump)	SAE J518	3 1/2 in	30 (435)	O
	Fastening thread	ASME B1.1	5/8-11UNC-2B; 35 <sup>7)</sup> (1.38) deep		
<b>S</b>	Suction port (with charge pump)	SAE J518	3 1/2 in	2 (30)	O
	Fastening thread	ASME B1.1	5/8-11UNC-2B; 35 <sup>7)</sup> (1.38) deep		
<b>T<sub>1</sub></b>	Drain port	ISO 11926 <sup>4)</sup>	1 5/8UN-2B; 20 (0.79) deep	10 (145)	O <sup>5)</sup>
<b>T<sub>2</sub></b>	Drain port	ISO 11926 <sup>4)</sup>	1 5/8UN-2B; 20 (0.79) deep	10 (145)	X <sup>5)</sup>
<b>T<sub>3</sub></b>	Drain port	ISO 11926 <sup>4)</sup>	1 5/8UN-2B; 20 (0.79) deep	10 (145)	X <sup>5)</sup>
<b>CR</b>	Pilot signal (CR only)	ISO 11926	9/16-18UNF-2B; 13 (0.51) deep	420 (6100)	O
<b>PR</b>	Pilot signal (PR only)	ISO 11926	9/16-18UNF-2B; 13 (0.51) deep	420 (6100)	O
<b>H3, H4</b>	Pilot signal (H3 and H4 only)	ISO 11926	9/16-18UNF-2B; 13 (0.51) deep	100 (1450)	O
<b>L5, L6</b>	Override power controller (only with L5 and L6)	ISO 11926	9/16-18UNF-2B; 13 (0.51) deep	100 (1450)	O
<b>X</b>	Pilot signal (S0 and DG only)	ISO 11926 <sup>4)</sup>	9/16-18UNF-2B; 13 (0.51) deep	420 (6100)	O
<b>M</b>	Measuring, control pressure	ISO 11926 <sup>4)</sup>	9/16-18UNF-2B; 13 (0.51) deep	420 (6100)	X
<b>M<sub>A</sub></b>	Measuring, pressure A	ISO 11926 <sup>4)</sup>	9/16-18UNF-2B; 13 (0.51) deep	420 (6100)	X
<b>P</b>	External control pressure (Ordering code position 8 version B or C = with external control pressure supply)	ISO 11926 <sup>4)</sup>	9/16-18UNF-2B; 13 (0.51) deep	50 (725)	O
	Port <b>P</b> is without function (Ordering code position 8 version A = without external control pressure supply)	ISO 11926 <sup>4)</sup>	3/4-16UNF-2B; 12.6 (0.50) deep	420 (6100)	X

- 1) Observe the instructions in the operating instructions concerning the maximum tightening torques.
- 2) Depending on the application, momentary pressure peaks can occur. Keep this in mind when selecting measuring devices and fittings.
- 3) Metric fastening thread is a deviation from standard.
- 4) The countersink can be deeper than as specified in the standard.

- 5) Depending on installation position, T<sub>1</sub>, T<sub>2</sub> or T<sub>3</sub> must be connected (see also Installation instructions on pages 64 and 65).
- 6) O = Must be connected (plugged when delivered)  
X = Plugged (in normal operation)
- 7) The thread depth is 30 mm (1.18 in) for the left pump direction of rotation

▼ **LR** – Power controller, fixed setting

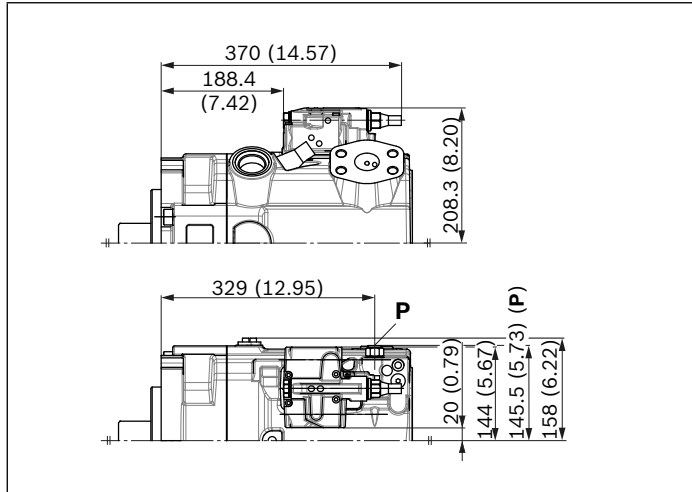

▼ **L3/L4** – Power controller, electric-proportional override

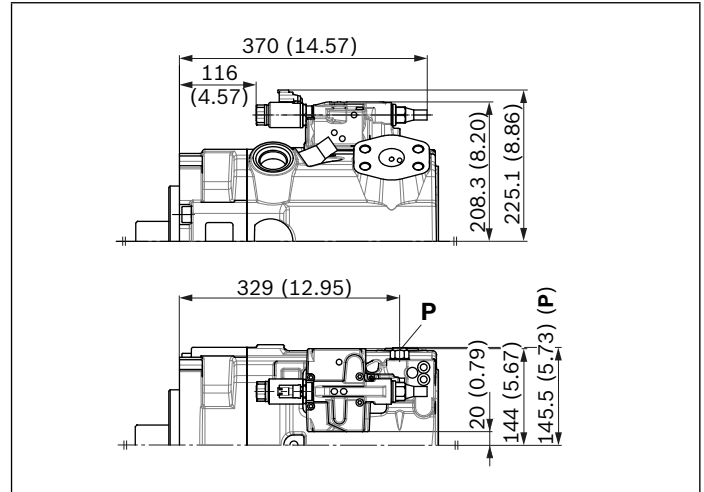

▼ **L5/L6** – Power controller, hydraulic override

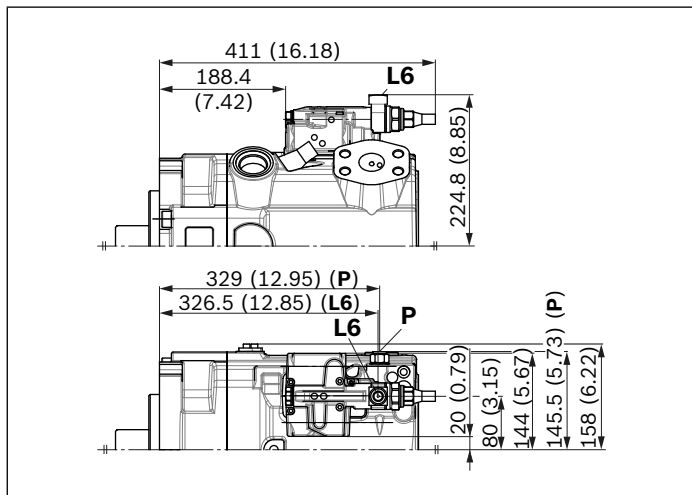

▼ **CR** – Power controller, hydraulic-proportional override, high pressure, with stop

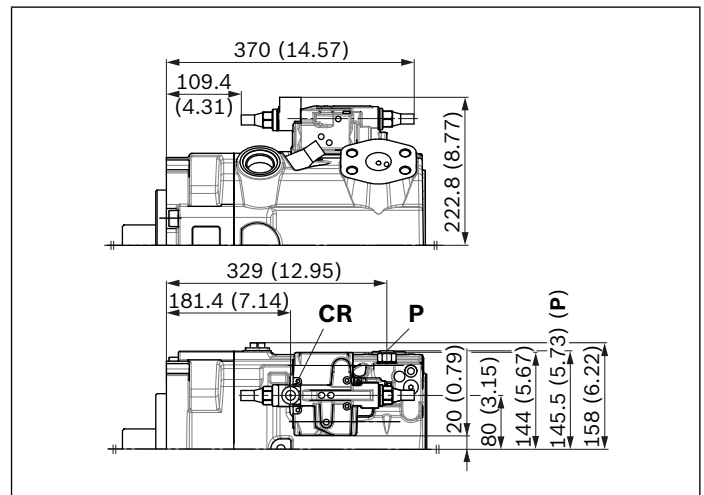

▼ **PR** – Power controller, hydraulic-proportional override, high pressure, without stop

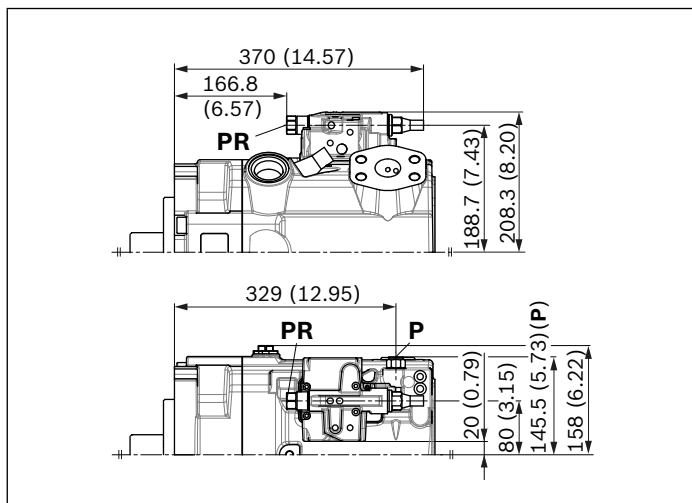

▼ **E1/E2** – Stroke control electric-proportional

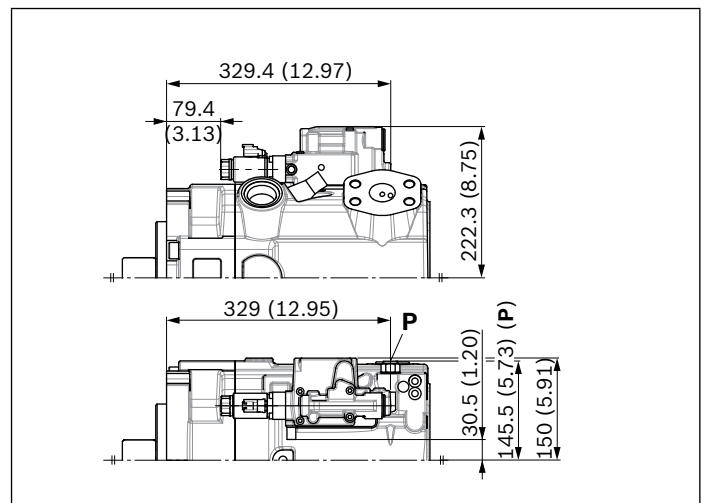

**Notice**

All controllers described with shuttle valve in **P** (some contrary to standard as per ordering code position 08)

▼ **H3/H4** – Stroke control, hydraulic-proportional, pilot pressure

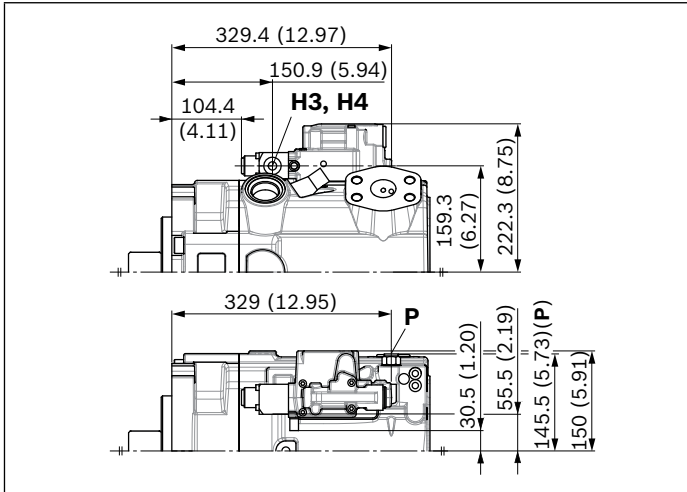

▼ **DR** – Pressure controller, fixed setting

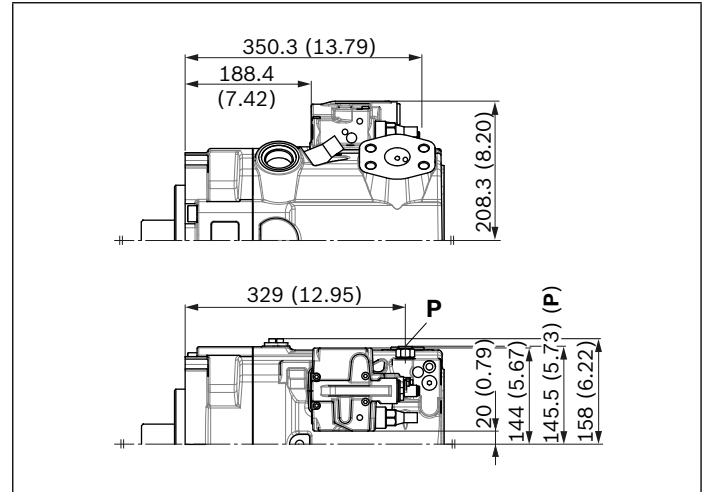

▼ **LRDRS0** – Power controller with pressure controller and load sensing, fixed setting

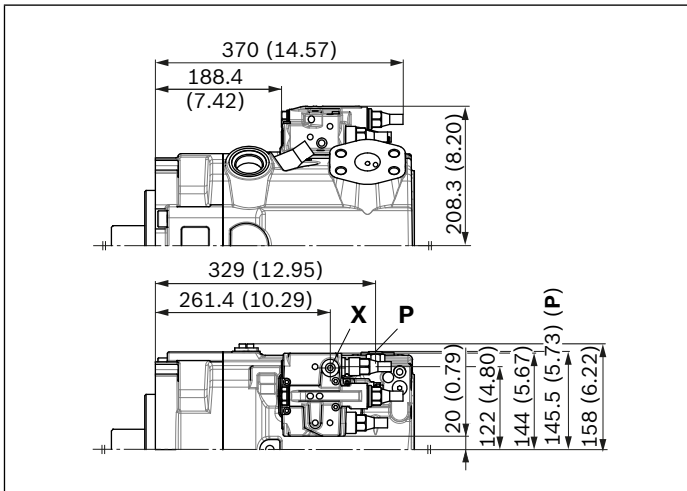

▼ **DG** – Pressure controller, hydraulic, remote controlled

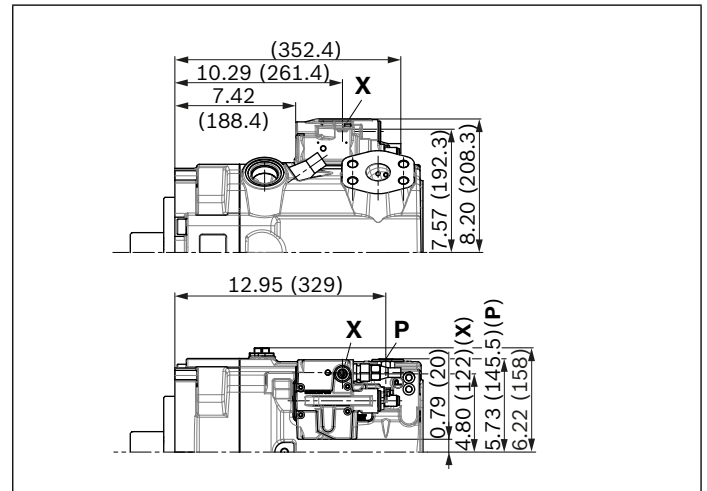

**Notice**

All controllers described with shuttle valve in **P** (some contrary to standard as per ordering code position 08)

## Dimensions, through drives

Flange SAE J744			Hub for splined shaft <sup>1)</sup>			Availability over sizes					Code
Diameter	Attachment <sup>2)</sup>	Designation	Diameter	Designation		110	145	175	210	280	
82-2 (A)	☉	A3	5/8 in	9T 16/32DP	S2	●	●	●	●	●	A3S2
			3/4 in	11T 16/32DP	S3	○	○	●	●	●	A3S3
101-2 (B)	☉	B3	7/8 in	13T 16/32DP	S4	●	●	●	●	●	B3S4
			1 in	15T 16/32DP	S5	●	●	●	●	●	B3S5
	☉	B5	7/8 in	13T 16/32DP	S4	●	●	●	●	●	B5S4
			1 in	15T 16/32DP	S5	○	○	●	●	○	B5S5

● = Available    ○ = On request

### ▼ 82-2 (A)

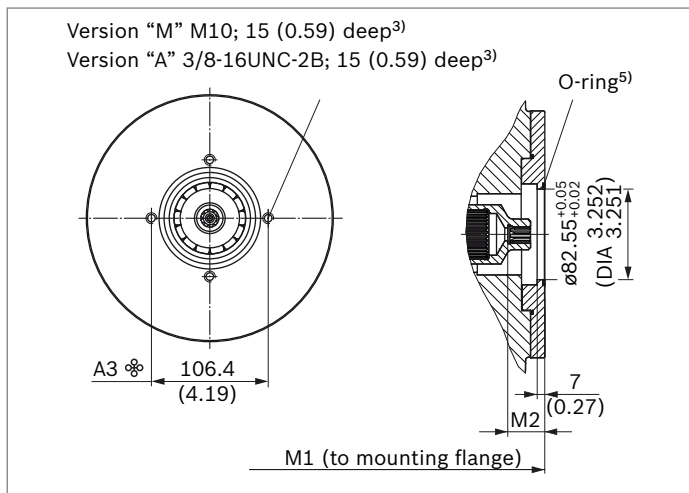

A3S2	NG	M1	M2
without charge pump	110	301 (11.85)	34 (1.39)
	145	326 (12.83)	40 (1.57)
	175	340.5 (13.41)	33.8 (1.33)
	210	357.8 (14.09)	33.8 (1.33)
	280	400 (15.75)	33.8 (1.33)
with charge pump	145	374.7 (14.75)	40 (1.57)
	175	389.5 (15.33)	33.8 (1.33)
	210	406.8 (16.02)	33.8 (1.33)
	280	438 (17.24)	33.8 (1.33)

A3S3	NG	M1	M2
without charge pump	175	340.5 (13.41)	40 (1.57)
	210	357.8 (14.09)	40 (1.57)
	280	400 (15.75)	40 (1.57)
with charge pump	175	389.5 (15.33)	40 (1.57)
	210	406.8 (16.02)	40 (1.57)
	280	438 (17.24)	40 (1.57)

- 1) According to ANSI B92.1a, 30° pressure angle, flat root, side fit, tolerance class 5
- 2) Mounting bores pattern viewed from through drive with control at top
- 3) Thread according to DIN 13, observe the general instructions on page 66 for the maximum tightening torques.

### ▼ 101-2 (B)

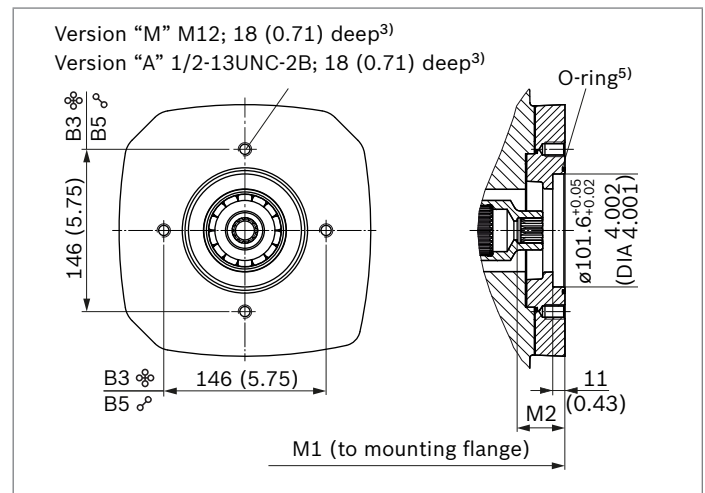

B3S4, B5S4	NG	M1	M2
without charge pump	110	312 (12.28)	43 (1.69)
	145	337 (13.27)	43 (1.69)
	175	355 (13.97)	43 (1.69)
	210	372.3 (14.65)	43 (1.69)
	280	414.5 (16.31)	43 (1.69)
with charge pump	145	385.7 (15.19)	43 (1.69)
	175	404 (15.90)	43 (1.69)
	210	421.3 (16.58)	43 (1.69)
	280	452.5 (17.81)	43 (1.69)

B3S4, B3S5	NG	M1	M2
without charge pump	110	312 (12.28)	48 (1.89)
	145	337 (13.27)	48 (1.89)
	175	355 (13.97)	48 (1.89)
	210	372.3 (14.65)	48 (1.89)
	280	414.5 (16.31)	48 (1.89)
	with charge pump	145	385.7 (15.18)
175		404 (15.90)	48 (1.89)
210		421.3 (16.58)	48 (1.89)
280		452.5 (17.81)	48 (1.89)

- 4) Thread according to ASME B1.1, observe the general instructions on page 66 for the maximum tightening torques.
- 5) O-ring included in the scope of delivery

Flange SAE J744			Hub for splined shaft <sup>1)</sup>			Availability over sizes					Code
Diameter	Attachment <sup>2)</sup>	Designation	Diameter	Designation		110	145	175	210	280	
127-2 (C)	☼	C3	1 1/4 in	14T 12/24DP	S7	●	●	●	●	●	C3S7
			1 1/2 in	17T 12/24DP	S9	○	○	●	●	●	C3S9
127-4 (C)	☼	C4	1 1/4 in	14 12/24DP	S7	○	-	●	●	●	C5S7
			1 1/4 in	14T 12/24DP	S7	●	●	●	●	○	C4S7

● = Available    ○ = On request

▼ 127-2 (C)

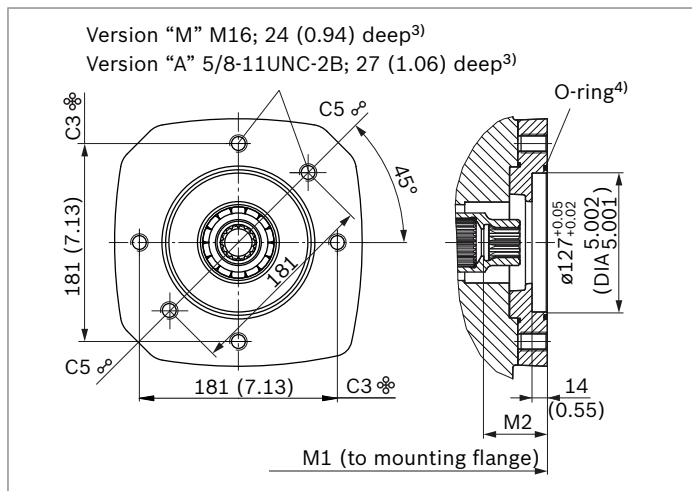

	NG	M1	M2
without charge pump	110	323 (12.72)	58 (2.28)
	145	348 (13.70)	58 (2.28)
	175	354.5 (13.96)	58.1 (2.29)
	210	371.8 (14.64)	58.1 (2.29)
	280	414 (16.30)	58.1 (2.29)
with charge pump	145	396.7 (15.62)	58 (2.28)
	175	403.5 (15.89)	58.1 (2.29)
	210	420.8 (16.57)	58.1 (2.29)
	280	452 (17.80)	58.1 (2.29)

	NG	M1	M2
without charge pump	175	359.5 (14.15)	64 (2.52)
	210	376.8 (14.83)	64 (2.52)
	280	414 (16.30)	63.8 (2.51)
with charge pump	175	408.5 (16.08)	64 (2.52)
	210	425.8 (16.76)	64 (2.52)
	280	452 (17.80)	63.8 (2.51)

	NG	M1	M2
without charge pump	175	354.5 (13.96)	58 (2.28)
	210	371.8 (14.64)	58 (2.28)
	280	414 (16.30)	58 (2.28)
with charge pump	175	403.5 (15.89)	58 (2.28)
	210	420.8 (16.57)	58 (2.28)
	280	452 (17.80)	58 (2.28)

▼ 127-4 (C)

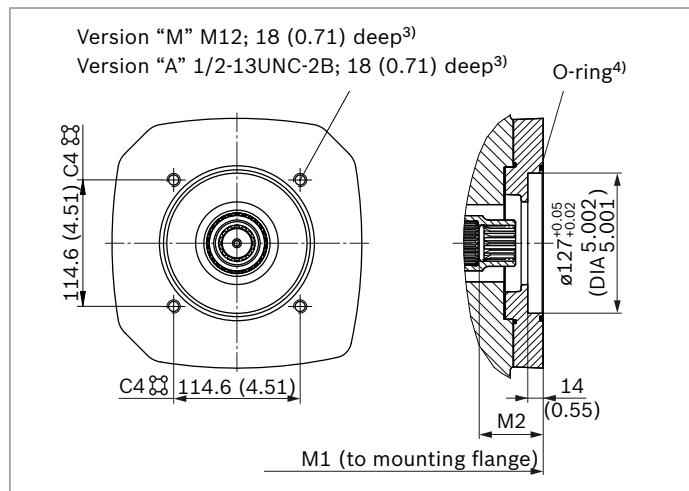

	NG	M1	M2
without charge pump	110	323 (12.72)	58 (2.28)
	145	348 (13.70)	58 (2.28)
	175	354.5 (13.96)	58 (2.28)
	210	371.8 (14.64)	58 (2.28)
	280	414 (16.30)	58 (2.28)
with charge pump	145	396.7 (15.62)	58 (2.28)
	175	403.5 (15.89)	58 (2.28)
	210	420.8 (16.57)	58 (2.28)

1) According to ANSI B92.1a, 30° pressure angle, flat root, side fit, tolerance class 5  
 2) Mounting bores pattern viewed from through drive with control at top  
 3) Thread according to DIN 13, observe the general instructions on page 66 for the maximum tightening torques.  
 4) O-ring included in the scope of delivery

Flange SAE J744			Hub for splined shaft <sup>1)</sup>			Availability over sizes					Code
Diameter	Attachment <sup>2)</sup>	Designation	Diameter		Designation	110	145	175	210	280	
152-4 (D)		D4	1 3/4 in	13T 8/16DP	T1	●	●	●	●	●	D4T1
165-4 (E)		E4	1 3/4 in	13T 8/16DP	T1	-	-	●	●	●	E4T1
			2 in	15T 8/16DP	T2	-	-	●	●	●	E4T2
			2 1/4 in	17T 8/16DP	T3	-	-	-	-	●	E4T3
			W60x2x28x9g <sup>5)</sup>		A4	-	-	-	-	●	E4A4

● = Available    ○ = On request

▼ **152-4 (D)**

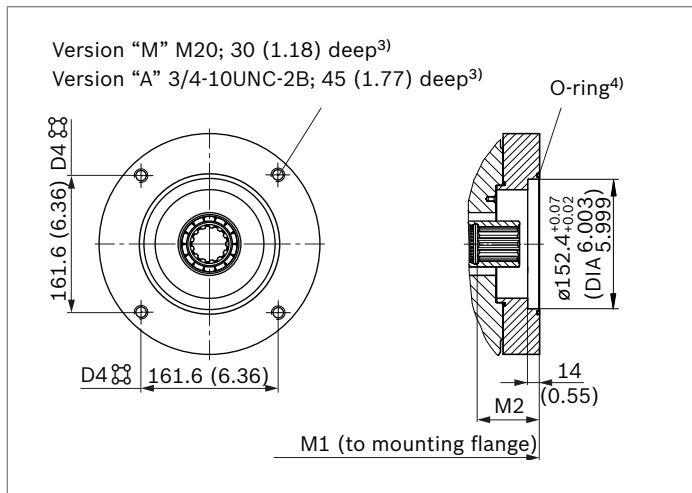

D4T1	NG	M1	M2
without charge pump	110	336 (13.23)	77 (3.03)
	145	361 (14.21)	76.8 (3.02)
	175	372.5 (14.67)	76.8 (3.02)
	210	389.8 (15.35)	76.8 (3.02)
	280	432 (17.01)	77 (3.03)
with charge pump	145	409.7 (16.13)	76.8 (3.02)
	175	421.5 (16.59)	76.8 (3.02)
	210	438.8 (17.28)	76.8 (3.02)
	280	470 (18.50)	77 (3.03)

▼ **165-4 (E)**

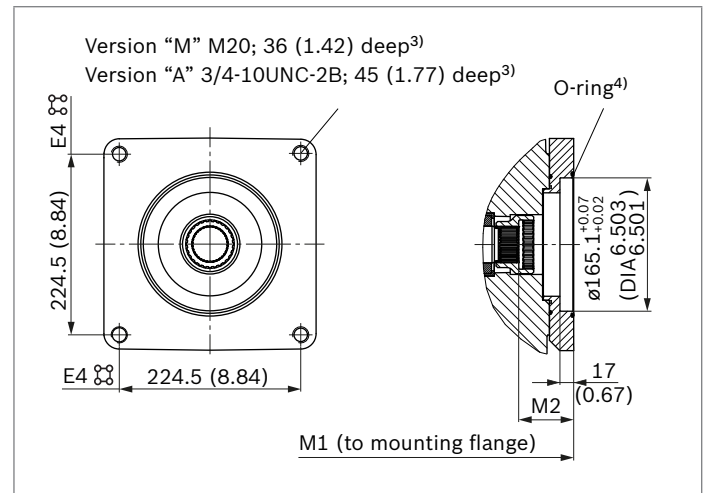

E4T1	NG	M1	M2	
without charge pump	175	355 (13.98)	77 (3.03)	
	210	389.8 (15.35)	77 (3.03)	
	280	432 (17.00)	77 (3.03)	
	with charge pump	175	421.5 (16.59)	77 (3.03)
	210	438.8 (17.27)	77 (3.03)	
	280	470 (18.50)	77 (3.03)	
E4T2	NG	M1	M2	
without charge pump	175	385.5 (15.18)	90 (3.54)	
	210	402.8 (15.86)	90 (3.54)	
	280	445 (17.52)	90 (3.54)	
with charge pump	175	434.5 (17.11)	90 (3.54)	
	210	451.8 (17.79)	90 (3.54)	
	280	483 (19.02)	90 (3.54)	
E4T3	NG	M1	M2	
without charge pump	280	445 (17.52)	90 (3.54)	
with charge pump	280	483 (19.02)	90 (3.54)	
E4A4	NG	M1	M2	
without charge pump	280	423 (16.65)	68 (2.68)	
with charge pump	280	461 (18.15)	68 (2.68)	

1) According to ANSI B92.1a, 30° pressure angle, flat root, side fit, tolerance class 5  
2) Mounting bores pattern viewed from through drive with control at top

3) Thread according to DIN 13, observe the general instructions on page 66 for the maximum tightening torques.  
4) O-ring included in the scope of delivery  
5) Hub N60x2x28x8H according to DIN 5480



**Overview of mounting options**

Through drive <sup>1)</sup>		Attachment options – 2 <sup>nd</sup> pump							
Flange	Hub for splined shaft	Code	A11VO/40 NG (shaft)	A10VO/31 NG (shaft)	A10VO/32 NG (shaft)	A4VG/32 NG (shaft)	A4VG/40 NG (shaft)	A10VO/52 and 53 NG (shaft)	External gear
82-2 (A)	5/8 in	A3S2	–	18 (U)	–	–	–	10, 18 (U)	Series F <sup>2)</sup>
	3/4 in	A3S3	–	18 (S, R)	–	–	–	10 (S), 18 (S, R)	
101-2 (B)	7/8 in	B_S4	–	28 (S, R); 45 (U, W)	–	–	–	28 (R, S); 45 (U, W)	Series N <sup>2)</sup>
	1 in	B_S5	–	45 (R, S)	–	28 (S)	–	45 (R, S); 60, 63 (U, W)	
127-2 (C)	1 1/4 in	C_S7	–	71 (R, S); 100 (U, W)	71 (R) (S)	40, 56, 71 (S)	45, 65 (S7)	85, 100 (U, W)	–
	1 1/2 in	C3S9	–	100 (S)	100 (S)	–	45, 65 (S9)	85, 100 (S)	PGH5
	1 1/4 in	C5S7	–	71 (S, R) 100 (U, W)	71 (S, R) 100 (U, W)	–	–	85, 100 (U, W)	–
127-4 (C)	1 1/4 in	C4S7	–	–	71 (R) (S)	–	65 (S7)	60, 63 (R, S) 85 (U, W)	–
	1 3/8 in	C4V8	–	–	–	–	85, 110 (V8)	–	–
152-4 (D)	1 1/4 in	D4S7	–	–	100 (U,W)	90 (U)	–	–	–
	1 3/8 in	D4V8	–	–	–	–	85, 110 (V8)	–	–
	1 3/4 in	D4T1	110, 145 (T1)	140 (S)	140 (S)	90, 125 (S)	145 (T1)	–	–
165-4 (E)	1 3/4 in	E4T1	–	–	–	180, 250 (S)	145, 175 (T1)	–	–
	2 in	E4T2	175, 210 (T2)	–	–	–	145 (T2)	–	–
	2 1/4 in	E4T3	280 (T3)	–	–	180, 250 (T)	175 (T3)	–	–
	W60	E4A4	280 (A4)	–	–	–	–	–	–

1) Additional through drives are available on request

2) Bosch Rexroth recommends special versions of the external gear pumps. Please contact us.

## Combination pumps A11V(L)O + A11V(L)O

### Total length A

A11VO (1 <sup>st</sup> pump)	A11VO (2 <sup>nd</sup> pump)						A11VLO (2 <sup>nd</sup> pump)					
	NG110	NG145	NG175	NG210	NG280	NG280	NG145	NG175	NG210	NG280	NG280	
	D4T1	D4T1	E4T2	E4T2	E4A4	E4T3	D4T1	E4T2	E4T2	E4A4	E4T3	
NG110	621 (24.45)	-	-	-	-	-	-	-	-	-	-	-
NG145	646 (25.43)	671 (26.42)	-	-	-	-	736.2 (28.98)	-	-	-	-	-
NG175	657.5 (25.89)	682.5 (26.87)	713 (28.07)	-	-	-	747.7 (29.44)	780 (30.71)	-	-	-	-
NG210	674.8 (26.57)	699.8 (27.55)	730.3 (28.75)	747.6 (29.43)	-	-	765 (30.12)	797.3 (31.00)	814.6 (32.07)	-	-	-
NG280	717 (28.23)	742 (29.21)	772.5 (30.41)	789.8 (31.09)	810 (31.90)	832 (32.76)	807.2 (31.78)	839.5 (33.05)	856.8 (33.73)	866 (34.09)	888 (34.96)	-

A11VLO (1 <sup>st</sup> pump)	A11VO (2 <sup>nd</sup> pump)						A11VLO (2 <sup>nd</sup> pump)					
	NG110	NG145	NG175	NG210	NG280	NG280	NG145	NG175	NG210	NG280	NG280	
	D4T1	D4T1	E4T2	E4T2	E4A4	E4T3	D4T1	E4T2	E4T2	E4A4	E4T3	
NG 145	694.7 (27.35)	719.7 (28.33)	-	-	-	-	784.9 (30.90)	-	-	-	-	-
NG175	706.5 (27.81)	731.5 (28.80)	762 (30.00)	-	-	-	796.7 (31.37)	829 (32.64)	-	-	-	-
NG210	723.8 (28.50)	748.8 (29.48)	779.3 (30.68)	796.6 (31.36)	-	-	814 (32.05)	846.3 (33.32)	863.6 (34.00)	-	-	-
NG280	755 (29.72)	780 (30.71)	810.5 (31.91)	827.8 (32.59)	848 (33.39)	870 (34.25)	845.2 (33.28)	877.5 (34.55)	894.8 (35.23)	904 (35.59)	926 (36.46)	-

By using combination pumps, it is possible to have independent circuits without the need for splitter gearboxes. When ordering combination pumps, the type designations of the 1<sup>st</sup> and 2<sup>nd</sup> pumps must be linked by a “+”.

#### Order example:

**A11VO280LRDRA00/40M(A)RVE4A41SE4A40-0+**

**A11VO280LRDRA00/40M(A)RVE4A41SU0000-0**

A tandem pump consisting of two equal sizes is permissible without additional supports assuming that the dynamic mass acceleration does not exceed maximum 10 g (= 98.1 m/s<sup>2</sup>). For combination pumps consisting of more than two pumps, the mounting flange must be rated for the permissible mass torque.

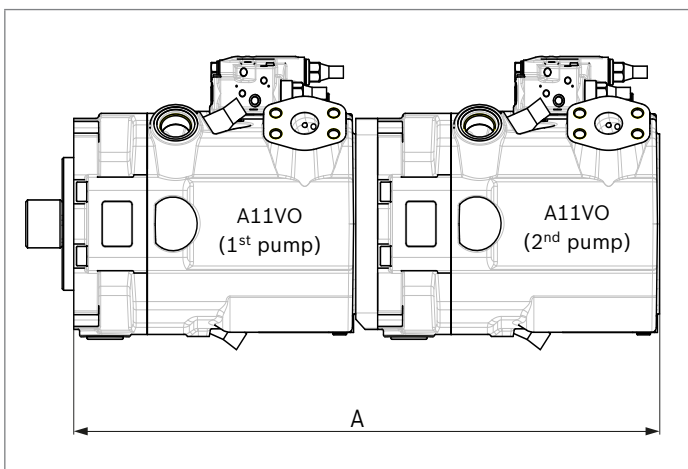

## Connector for solenoids

### DEUTSCH DT04-2P-EP04

Molded, 2-pin, without bidirectional suppressor diode, with mating connector mounted, results in the following type of protection:

- ▶ IP67 (DIN/EN 60529) and
- ▶ IP69K (DIN 40050-9)

#### ▼ Switching symbol

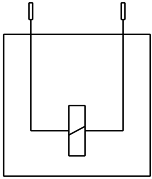

#### ▼ Mating connector DEUTSCH DT06-2S-EP04

Consisting of	DT designation
1 housing	DT06-2S-EP04
1 wedge	W2S
2 sockets	0462-201-16141

The mating connector is not included in the scope of delivery. This can be supplied by Bosch Rexroth on request (material number R902601804).

#### Notice

If necessary, you can change the position of the connector by turning the solenoid.  
The procedure is defined in the instruction manual.

### AMP Junior-Timer, 2-pin

Type of protection:

- ▶ IP69K (DIN 40050-9)

The mating connector is not included in the scope of delivery. This can be supplied by Bosch Rexroth on request (material number R901022127); see also data sheet 08006.

- ▶ Outer diameter of conductor 2.2 mm (0.09 in) to 3.0 mm (0.12 in)

#### Manual override

When power supply to the vehicle is interrupted, maximum operating pressure can be established by means of a manual override so that the vehicle can be driven under its own power from a danger zone.

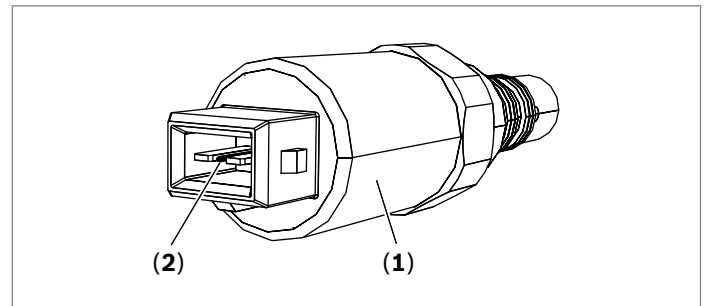

To activate the manual override:

- ▶ Unplug the electrical connector from the pressure reducing valve (1).
- ▶ Using a pointed tool, press both PINs (2) in up to the stop.  
Both PINs must remain in the depressed position!

## Installation instructions

### General

The axial piston unit must be filled with hydraulic fluid and air bled during commissioning and operation. This must also be observed following a longer standstill as the axial piston unit may empty via the hydraulic lines.

Particularly in the installation position “drive shaft upwards”, filling and air bleeding must be carried out completely as there is, for example, a danger of dry running.

The case drain fluid in the pump housing must be directed to the reservoir via the highest available drain port (**T**<sub>1</sub>, **T**<sub>2</sub>, **T**<sub>3</sub>).

For combination pumps, the leakage must be drained off at each pump.

If a shared drain line is used for several units, make sure that the respective case pressure is not exceeded. The shared drain line must be dimensioned to ensure that the maximum permissible case pressure of all connected units is not exceeded in any operating conditions, specifically on cold start. If this is not possible, separate drain lines must be laid if necessary.

To achieve favorable noise values, decouple all connecting lines using elastic elements and avoid above-reservoir installation.

In all operating conditions, the suction line and drain line must flow into the reservoir below the minimum fluid level. The permissible suction height  $h_s$  results from the overall loss of pressure. However, it must not be higher than  $h_{S \max} = 800 \text{ mm}$  (31.50 in). The minimum suction pressure at port **S** must also not fall below 0.8 bar (12 psi) absolute (without charge pump) or 0.7 bar (11 psi) absolute (with charge pump) during operation and during a cold start. When designing the reservoir, ensure adequate distance between the suction line and the case drain line. This prevents the heated, return flow from being drawn directly back into the suction line.

### Notice

In certain installation positions, an influence on the control characteristic can be expected. Gravity, dead weight and case pressure can cause minor shifts in control characteristic curves and changes in response time.

### Installation position

See the following examples **1** to **9**.

Further installation positions are available upon request.

Recommended installation position: **1** and **2**

### Below-reservoir installation (standard)

Below-reservoir installation means that the axial piston unit is installed outside of the reservoir and below the minimum fluid level of the reservoir.

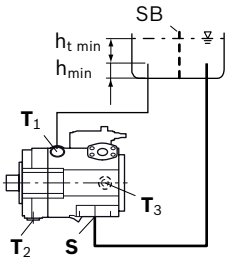
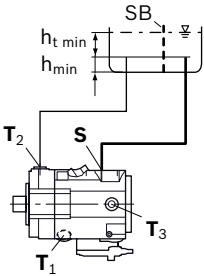
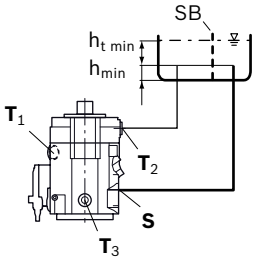
Installation position	Air bleed	Filling
<b>1</b> 	<b>T</b> <sub>1</sub>	<b>S</b> + <b>T</b> <sub>1</sub>
<b>2</b> 	<b>T</b> <sub>2</sub>	<b>S</b> + <b>T</b> <sub>2</sub>
<b>3</b> 	<b>T</b> <sub>2</sub>	<b>S</b> + <b>T</b> <sub>2</sub>
Key		
<b>L</b>	Filling / air bleeding	
<b>S</b>	Suction port	
<b>T</b>	Drain port	
<b>SB</b>	Baffle (baffle plate)	
$h_{t \min}$	Minimum required immersion depth (200 mm (7.87 in))	
$h_{\min}$	Minimum required distance to reservoir bottom (100 mm (3.94 in))	
$h_{ES \min}$	Minimum necessary height required to protect the axial piston unit from draining (25 mm (1 in))	
$h_{S \max}$	Maximum permissible suction height (800 mm (31.50 in))	

### Above-reservoir installation

Above-reservoir installation means that the axial piston unit is installed above the minimum fluid level of the reservoir. To prevent the axial piston unit from draining, a height difference  $h_{ES\ min}$  of at least 25 mm (1 in) at port **T<sub>2</sub>** is required in position 6. Observe the maximum permissible suction height  $h_{S\ max} = 800\ mm\ (31.50\ in)$ . The above-reservoir installation is not permitted for units with charge pump (A11VLO).

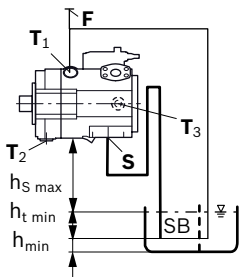
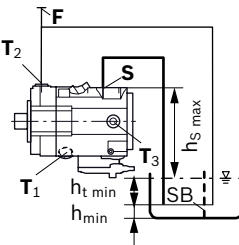
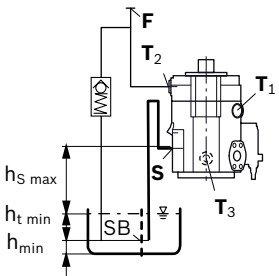
Installation position	Air bleed	Filling
<b>4</b> 	<b>F</b>	<b>T<sub>1</sub> (F)</b>
<b>5</b> 	<b>F</b>	<b>T<sub>2</sub> (F)</b>
<b>6</b> 	<b>F</b>	<b>T<sub>2</sub> (F)</b>

### Inside-reservoir installation

Inside-reservoir installation is when the axial piston unit is installed in the reservoir below the minimum fluid level. The axial piston unit is completely below the hydraulic fluid. If the minimum fluid level is equal to or below the upper edge of the pump, see chapter “**Above-reservoir installation**”. Axial piston units with electric components (e.g. electric controls, sensors) must not be installed in a reservoir below the fluid level.

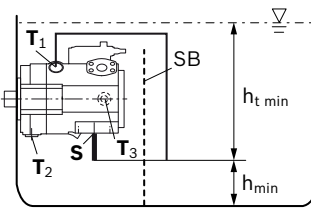
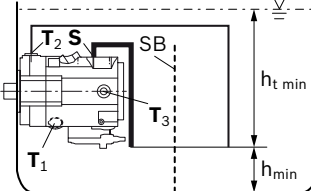
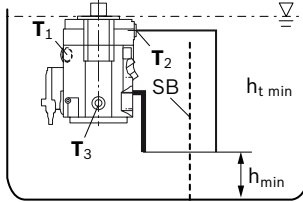
Installation position	Air bleed	Filling
<b>7</b> 	Via the highest available port <b>T<sub>1</sub></b>	Automatically via the open port <b>T<sub>1</sub></b> due to the position under the hydraulic fluid level
<b>8</b> 	Via the highest available port <b>T<sub>2</sub></b>	Automatically via the open port <b>T<sub>2</sub></b> due to the position under the hydraulic fluid level
<b>9</b> 	Via the highest available port <b>T<sub>2</sub></b>	Automatically via the open port <b>T<sub>2</sub></b> due to the position under the hydraulic fluid level

### Notice

Port **F** is part of the external piping and must be provided on the customer side to make filling and air bleeding easier.

## Project planning notes

- ▶ The A11V(L)O axial piston variable pump is designed to be used in open circuits.
- ▶ The project planning, installation and commissioning of the axial piston unit requires the involvement of qualified skilled personnel.
- ▶ Before using the axial piston unit, please read the corresponding instruction manual completely and thoroughly. If necessary, these can be requested from Bosch Rexroth.
- ▶ Before finalizing your design, please request a binding installation drawing.
- ▶ The specified data and notes contained herein must be observed.
- ▶ Depending on the operating conditions of the axial piston unit (operating pressure, fluid temperature), the characteristic curve may shift.
- ▶ The characteristic curve may also shift due to the dither frequency or control electronics.
- ▶ Preservation: Our axial piston units are supplied as standard with preservative protection for a maximum of 12 months. If longer preservative protection is required (maximum 24 months), please specify this in plain text when placing your order. The preservation periods apply under optimal storage conditions, details of which can be found in the data sheet 90312 or the instruction manual.
- ▶ Not all versions of the product are approved for use in a safety function pursuant to ISO 13849. Please consult the responsible contact person at Bosch Rexroth if you require reliability parameters (e.g.  $MTTF_d$ ) for functional safety.
- ▶ Depending on the type of control used, electromagnetic effects can be produced when using solenoids. When a direct current is applied, solenoids do not cause electromagnetic interference nor is their operation impaired by electromagnetic interference.  
Other behavior can result when a modulated direct current (e.g. PWM signal) is applied. Potential electromagnetic interference for persons (e.g. persons with a pacemaker) and other components must be tested by the machine manufacturer.

- ▶ Pressure controllers are not safeguards against pressure overload. Be sure to add a pressure relief valve to the hydraulic system.
- ▶ Working ports:
  - The ports and fastening threads are designed for the specified maximum pressure. The machine or system manufacturer must ensure that the connecting elements and lines correspond to the specified application conditions (pressure, flow, hydraulic fluid, temperature) with the necessary safety factors.
  - The working ports and function ports are only intended to accommodate hydraulic lines.

## Safety instructions

- ▶ During and shortly after operation, there is a risk of getting burnt on the axial piston unit and especially on the solenoids. Take appropriate safety measures (e.g. by wearing protective clothing).
- ▶ Moving parts in control equipment (e.g. valve pistons) can, under certain circumstances get blocked in position as a result of contamination (e.g. impure hydraulic fluid, abrasion, or residual dirt from components). As a result, the hydraulic fluid flow and the build-up of torque in the axial piston unit can no longer respond correctly to the operator's specifications. Even the use of various filter elements (external or internal flow filter) will not rule out a fault but merely reduce the risk. The machine/system manufacturer must test whether remedial measures are needed on the machine for the application concerned in order to set the consumer being driven to a safe position (e.g. safe stop) and if necessary to ensure it is properly implemented.



**Bosch Rexroth AG**

Mobile Applications  
An den Kelterwiesen 14  
72160 Horb a.N., Germany  
Phone +49 7451 92-0  
info.ma@boschrexroth.de  
www.boschrexroth.com

© Bosch Rexroth AG 2016. All rights reserved, also regarding any disposal, exploitation, reproduction, editing, distribution, as well as in the event of applications for industrial property rights. The data specified within only serves to describe the product. No statements concerning a certain condition or suitability for a certain application can be derived from our information. The information given does not release the user from the obligation of own judgment and verification. It must be remembered that our products are subject to a natural process of wear and aging.